

**SINGER**  
**110W150**

# USE ONLY **SINGER**\* OILS and LUBRICANTS

*They insure freedom from lubricating trouble and  
give longer life to sewing equipment*

*The following are the correct lubricants for this machine:*

**TYPE B** — MANUFACTURING MACHINE OIL, HEAVY GRADE

*When a stainless oil is desired, use:*

**TYPE D** — MANUFACTURING MACHINE OIL, STAINLESS,  
HEAVY GRADE

**GEAR LUBRICANT**

This specially prepared grease is recommended for gear  
lubrication on manufacturing sewing machines.

## OTHER **SINGER** LUBRICANTS

**TYPE E** — THREAD LUBRICANT

For lubricating the needle thread of sewing machines for  
stitching fabrics or leather where a thread lubricant is  
required.

**TYPE F** — MOTOR OIL

For oil lubricated motors and plain bearings in power  
tables and transmitters.

**NOTE:** All of the above oils are available in 1 quart,  
1 gallon and 5 gallon cans or in 55 gallon drums.

**BALL BEARING LUBRICANT**

This pure grease is specially designed for the lubrication  
of ball bearings and ball thrust bearings of motors and  
electric transmitters, ball bearing hangers of power tables,  
etc. **Furnished in 1 lb. and 4 lb. tins.**

1943w

# INSTRUCTIONS FOR USING AND ADJUSTING **SINGER**\* SEWING MACHINE

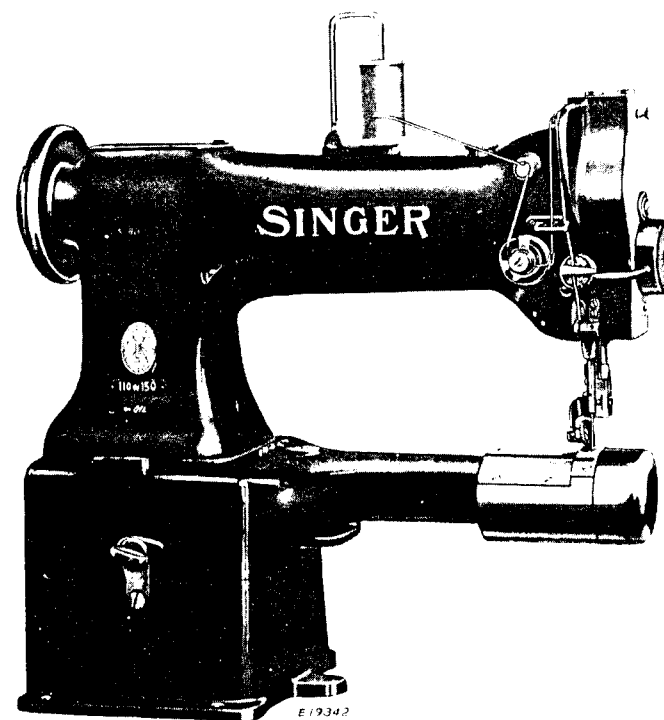

## 110W150

\*A TRADE MARK OF

THE SINGER MANUFACTURING COMPANY

## TO ALL WHOM IT MAY CONCERN:

The improper placing or renewal of the Trade Mark "**SINGER**" or any other of the Trade Marks of The Singer Manufacturing Company (all of which are duly Registered Trade Marks) on any machine that has been repaired, rebuilt, reconditioned, or altered in any way whatsoever outside a **SINGER** factory or an authorized **SINGER** agency is forbidden.

### THE IMPORTANCE OF USING **SINGER**\* PARTS AND NEEDLES IN **SINGER** MACHINES

The successful operation of **SINGER** machines can only be assured if **SINGER** parts and needles are used. Supplies are available at all **SINGER** Shops for the Manufacturing Trade, and mail orders will receive prompt attention.

**SINGER** Needles should be used  
in **SINGER** Machines  
These Needles and their Containers  
are marked with the  
Company's Trade Mark "**SIMANCO**.\*" 1

Needles in Containers marked  
"**FOR SINGER MACHINES**"  
are NOT **SINGER** made needles. 2

Copyright, U. S. A., 1914, 1922, 1925 and 1933  
by The Singer Manufacturing Company  
All Rights Reserved for All Countries

## DESCRIPTION

Machine 110 w 150 has a cylinder bed and the balance wheel at the left hand. It is fitted with a continuously moving wheel feed in combination with a needle feed and is intended for use in the manufacture of shoes and similar leather work. It has one needle and a gear driven rotary vertical sewing hook and makes the lock stitch. The length of stitch is controlled by interchangeable gears and adjustment of needle bar driving eccentric.

### Speed

The maximum speed recommended for Machine 110 w 150 is 3000 stitches per minute. The machine should be run slower than the maximum speed at first, until the parts which are in movable contact have become glazed by their action upon each other. When the machine is in operation, the balance wheel should turn over toward the operator.

### Needles

Needles for Machine 110 w 150 are of Class and Variety 16 x 4, and are furnished in sizes 9, 10, 11, 13, 14, 16, 17 and 18.

The size of the needle to be used should be determined by the size of the thread, which must pass freely through the eye of the needle. If rough or uneven thread is used, or if it passes with difficulty through the eye of the needle, the successful use of the machine will be interfered with. Use smooth finish thread of the same size for the needle and the bobbin.

Orders for needles should specify the **quantity** required, the **size** number, also the **class** and **variety** numbers separated by the letter "x."

The following is an example of an intelligible order:

"100 No. 13, 16 x 4 Needles."

The best results will be obtained in using the needles furnished by the Singer Sewing Machine Company.

### Thread

Use left twist thread for the needle. Either left or right twist thread may be used for the bobbin.

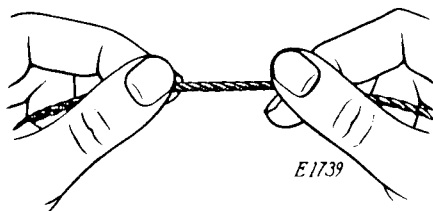

Fig. 2. How to Determine the Twist

Hold the thread as shown above. Then turn the thread over toward you between the thumb and forefinger of the right hand; if left twist, the strands will wind tighter; if right twist, the strands will unwind.

### To Set the Needle

Turn the balance wheel over toward you until the needle bar moves up to its highest point, loosen the set screw in the lower end of the needle bar and put the needle up into the bar as far as it will go, with the long groove of the needle toward the left and the eye directly in line with the arm of the machine, then securely tighten the set screw.

### To Remove the Bobbin

Draw out the cylinder end cover (B, Fig. 5) at the right of the needle. Insert the finger nail of the forefinger under the latch (A, Fig. 5), raise the latch and lift out the bobbin.

### To Wind the Bobbin

(See Fig. 3)

Fasten the bobbin winder on the table at the left of the machine with its pulley in front of the machine belt so that when the pulley is pushed back it will come in contact with the belt.

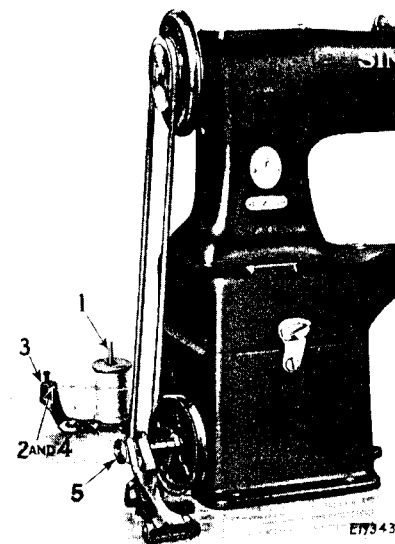

Fig. 3. Winding the Bobbin

Fasten the spool holder for the bobbin winder near the back edge of the table with its tension stud directly in line with the bobbin on the bobbin winder spindle as shown in Fig. 3.

Having placed the bobbin on the bobbin winder spindle (5) and pushed it on as far as it will go, put the spool of thread on the spool pin (1), lead the thread under the wire thread guide (2), around the back and between the tension discs (3), and through the wire thread guide (4). Wind the end of the thread around the bobbin a few times and push the bobbin winder pulley over against the machine belt, then start the machine. If the thread does not wind evenly on the bobbin, swing the spool holder to the right or left as desired. When sufficient thread has been wound upon the bobbin, the bobbin winder will stop automatically. Bobbins can be wound while the machine is stitching.

### To Replace the Bobbin and Thread the Bobbin Case

Hold the bobbin between the thumb and forefinger of the right hand, the thread drawing on the bottom from left to right

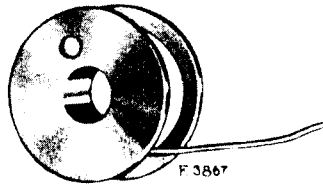

Fig. 4. Direction of Thread on Bobbin

(see Fig. 4) and place it on the centre stud of the bobbin case, then push down the latch (A) as shown in Fig. 5. Draw the thread into the slot (1, Fig. 5), under and back of the projection (2, Fig. 5), leaving a loose end of thread about two inches long above the cylinder end cover. When closing the cylinder end cover, leave just enough space for the thread to pass through.

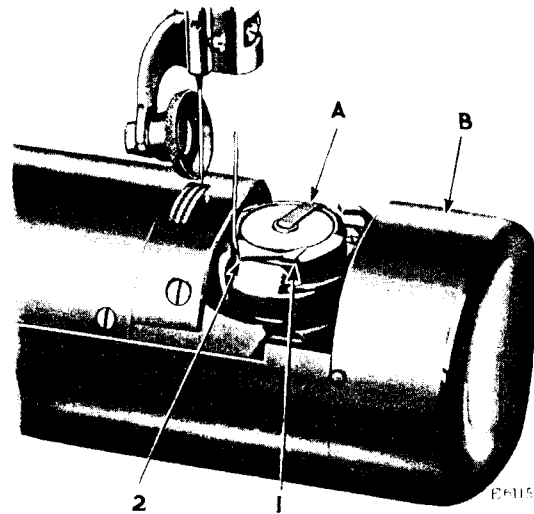

Fig. 5. Bobbin Case Threaded

### To Thread the Needle

Pass the thread from the spool holder from left to right through the thread retainer (1) at the front of the machine, down,

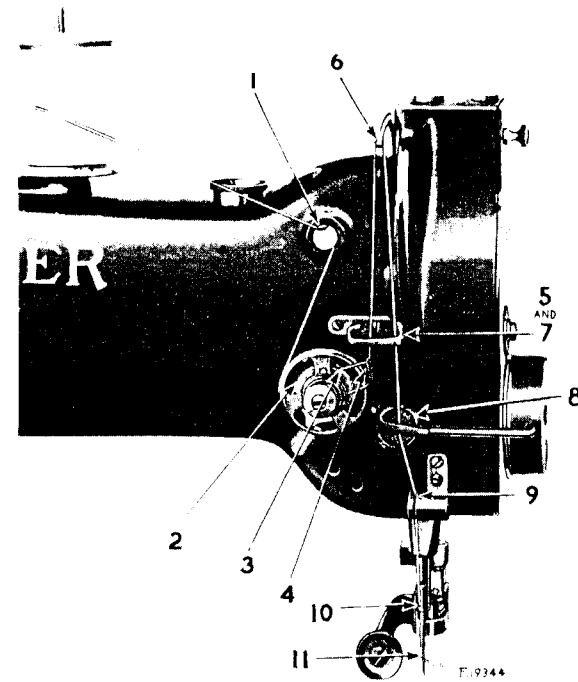

Fig. 6. Threading the Needle

under from left to right between the tension discs (2); pull the thread up under the thread controller spring (4) until it enters the retaining fork (3), then pass the thread up through the thread guide (5) and from left to right through the hole (6) in the end of the thread take-up lever, down through the thread guide (7), over the oil pad (8), into the thread nipper (9), down through the hole (10) at the lower end of the needle bar and from left to right through the eye of the needle (11). Draw about two inches of thread through the eye of the needle with which to commence sewing.

### To Prepare for Sewing

With the right hand, hold the end of the needle thread, leaving it slack from the hand to the needle, turn the balance wheel over toward you until the needle moves down and up again to its highest point, thus catching the bobbin thread; draw up the needle thread and the bobbin thread will come with it through the hole in the throat plate. Lay the threads back under the roller presser.

### To Commence Sewing

Place the material beneath the roller presser, lower the roller presser and commence to sew, turning the balance wheel over toward you.

### To Remove the Work

Stop the machine with the thread take-up lever at its highest point, raise the roller presser, draw the work back and cut the threads close to the leather.

### To Regulate the Pressure on the Material

The pressure on the material is regulated by the hexagon screw (R, Fig. 14) at the back of the machine, the screw acting on a flat spring. To increase the pressure, turn this screw downwardly. To decrease the pressure, turn this screw upwardly.

### Tensions

The needle and bobbin threads should be locked in the centre of the thickness of the material, thus:



Fig. 7. Perfect Stitch

If the tension on the needle thread is too tight, or if that on the bobbin thread is too loose, the needle thread will lie straight along the upper surface of the material, thus:



Fig. 8. Tight Needle Thread Tension

If the tension on the bobbin thread is too tight, or if that on the needle thread is too loose, the bobbin thread will lie straight along the under side of the material, thus:



Fig. 9. Loose Needle Thread Tension

### To Regulate the Tensions

The tension on the needle thread is regulated by the thumb nut (W, Fig. 17) at the front of the tension discs on the front of the machine. To increase the tension, turn this thumb nut over to the right. To decrease the tension, turn this thumb nut over to the left.

The tension on the bobbin thread is regulated by means of the screw nearest the centre of the tension spring on the outside of the bobbin case.

### To Change Length of Stitch

The length of stitch is controlled by the stitch regulating gears (C and D, Fig. 10) at the left of the underside of the bed

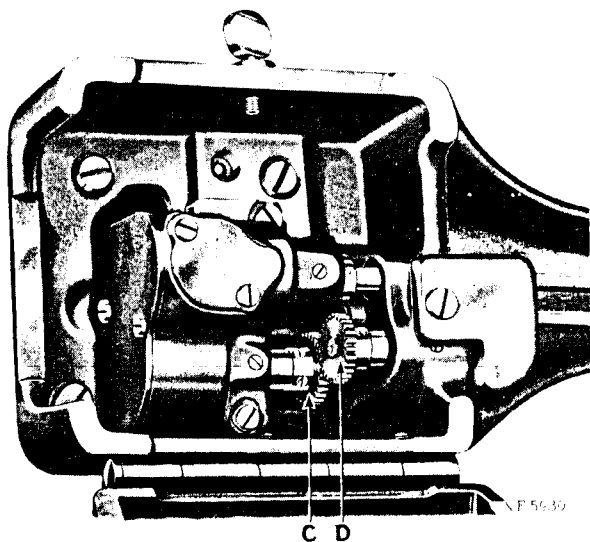

Fig. 10. View of Machine, Showing Stitch Regulating Gears

of the machine. When it is desired to change the length of stitch, it will be necessary to change both of these gears. To remove the stitch regulating gears, loosen the two screws in the hub of each of the gears and withdraw the gears from the shafts.

Following is a list of the stitch regulating gears made for use with the machine and the number of stitches per inch made by each pair of gears:

REGULATING GEAR (C, FIG. 10)	COUNTER-SHAFT GEAR (D, FIG. 10)	STITCHES PER INCH
239026	239018	13
239025	239019	14
239024	239020	15
239023	239021	16½
239022	239022	18
239021	239023	19
239020	239024	20½
239019	239025	22
239018	239026	24

With the exception of Gears 239022, two different lengths of stitches can be produced by reversing the pair of gears on the shafts, as shown in the above list.

As regularly sent out, the machine is fitted with stitch regulating gears for making 16½ and 19 stitches per inch. Other gears for producing different lengths of stitches, as shown on the preceding page, may be purchased, or if so specified, the machine will be fitted with any pair of gears selected.

The stitch regulating gears (C and D, Fig. 10) are marked with numerals indicating the part number, and when selecting the gears, care must be taken to see that the gears to be used are marked with the numbers which correspond to those indicated in the table for producing the required number of stitches per inch.

Having selected the pair of gears desired, place them on the shafts as shown in Fig. 10, having the position screw in the hub of each gear enter the groove in the shaft. See that the gears are pushed as far as they will go on the shafts, then securely tighten the two screws in each gear.

### To Regulate the Amount of Travel of the Needle Bar

When the stitch regulating gears (C and D, Fig. 10) have been changed to produce a different length of stitch, the throw or

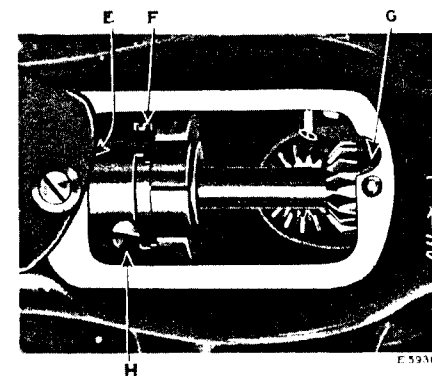

Fig. 11. Adjustment for Regulating Amount of Travel of Needle Bar

amount of travel of the needle bar must also be changed, so that the needle will move forward in unison with the wheel feed for each stitch.

Swing back the cover plate at the top of the machine and loosen the screw (F, Fig. 11) in the needle bar driving eccentric on the arm shaft. To increase the throw or amount of travel of the needle bar for a longer stitch, turn the large screw (H, Fig. 11) on the needle bar driving eccentric over to the left or upwardly.

To decrease the throw of the needle bar for a shorter stitch, turn the large screw (H) over to the right or downwardly. When the required throw of the needle bar is obtained, firmly tighten the screw (F).

#### To Raise or Lower the Feed Wheel

Remove the cylinder end cover (B, Fig. 5).

The height of the feed wheel is regulated by the two adjusting screws (K and M, Fig. 12), one of these screws being located at

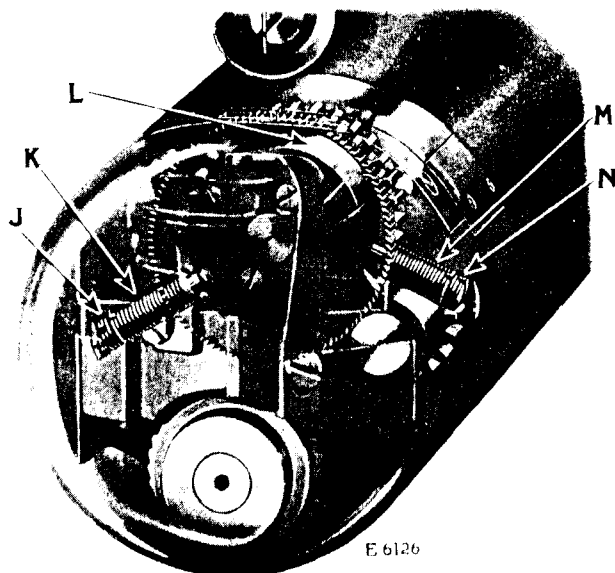

Fig. 12. "X-Ray" View of End of Cylinder Bed Showing Adjustments for Raising and Lowering Feed Wheel

each side of the cylinder in line with the feed wheel bracket (L, Fig. 12). At the back of each adjusting screw is a check screw as shown at J and N in Fig. 12. Remove both of these check screws. To raise the feed wheel, turn the adjusting screw (M) to the left, then turn the adjusting screw (K) to the right until the feed wheel is at the desired height, then turn the screw (M) to the right until it lightly touches the bracket. To lower the feed wheel, turn the adjusting screw (K) to the left until the feed wheel is at the desired height, then turn the adjusting screw (M) to the right until it lightly touches the bracket (L). Replace the two check screws (J and N, Fig. 12) and securely tighten them against the adjusting screws.

The feed wheel should be set so that slightly less than the full depth of the teeth will project through the feed wheel slot in the throat plate.

#### To Oil the Machine

To ensure easy running and prevent unnecessary wear of the parts which are in movable contact, the machine requires oiling, and when in continuous use, it should be oiled at least twice each day. Use "TYPE B" or "TYPE D" OIL, sold only by Singer Sewing Machine Company. For description of oils, see inside front cover.

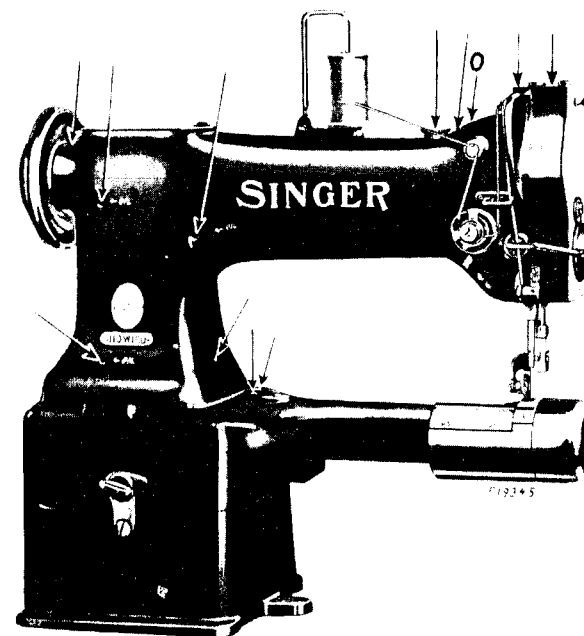

Fig. 13. Front View of Machine. Showing Oiling Points

The places where the machine should be oiled are indicated in Figs. 13, 14, 15 and 16, by arrows pointing to the oil holes and bearings.

Oil the bobbin case bearing in the hook race each time a bobbin is replaced.

Swing back the cover at the top of the machine and apply oil to the gears and needle bar driving eccentric thus uncovered.



14

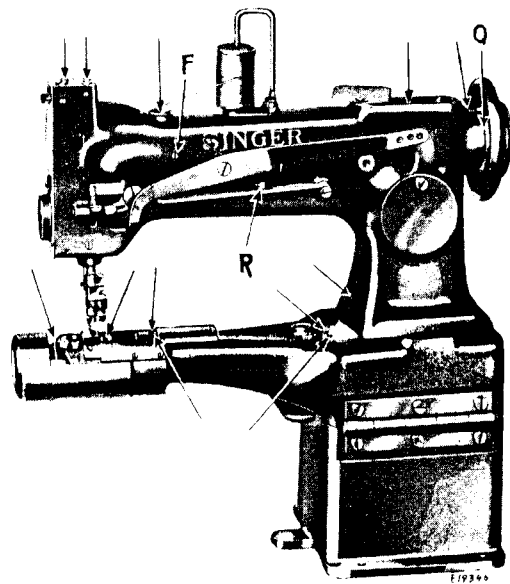

Fig. 14. Back View of Machine, Showing Oiling Points

Occasionally remove the cover (S, Fig. 15) of the gear case on the underside of the bed of the machine and fill the gear case

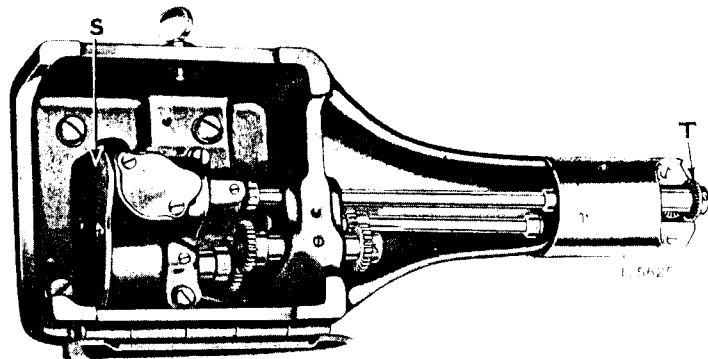

Fig. 15. Base View of Machine, Showing Oiling Points

with **SINGER GEAR LUBRICANT**, a grease which is especially prepared for the purpose. When removing the cover (S) be careful not to damage the paper gasket under the cover. If this gasket is torn, the grease will leak out of the gear case when the cover is replaced.

15

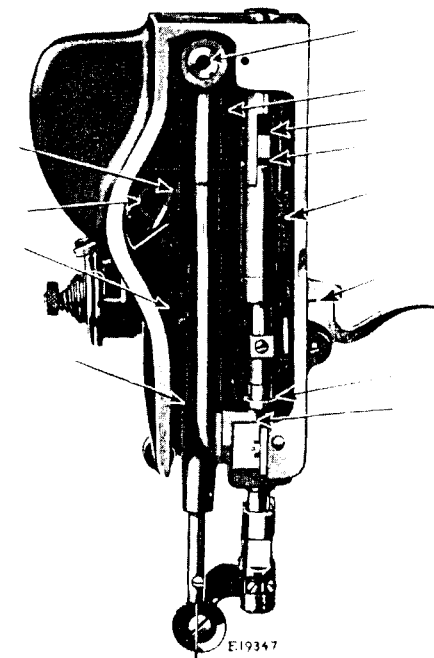

Fig. 16. End View of Machine, Showing Oiling Points

Loosen the thumb screw in the upper end of the face plate, turn the face plate upward and oil the wick and bearings which are thus uncovered, then turn down the face plate and tighten the thumb screw.

#### To Adjust the Thread Lubricator

To ensure satisfactory results, **SINGER THREAD LUBRICANT** should be used in the thread lubricator which is attached to the face plate.

When replenishing the lubricant supply, fill the reservoir to about  $\frac{1}{8}$  inch below the filler hole.

The amount of lubrication of the thread is controlled by raising or lowering the felt pad holder above or below the level of the lubricant. For more lubricant, lower the felt pad holder. For less lubricant, raise the felt pad holder.

# INSTRUCTIONS FOR ADJUSTERS AND MACHINISTS

## Thread Controller

The function of the thread controller spring is to hold back the slack of the upper thread until the eye of the needle nearly

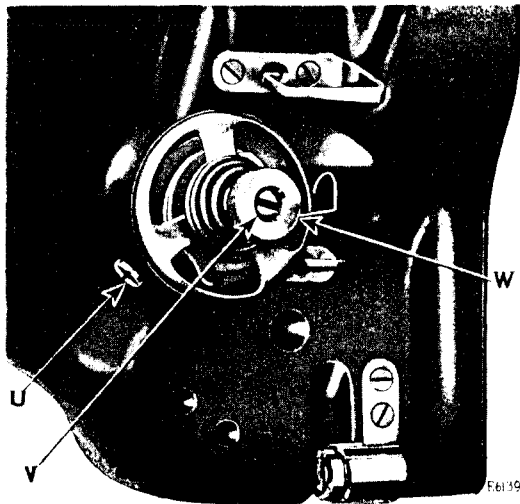

Fig. 17

reaches the goods in its descent, as without this controlling action of the spring, the slack thread or silk (more especially silk) will sometimes be penetrated by the point of the needle as the needle is descending. It may be found advisable to increase the tension of the spring for coarse thread, or lessen it for fine thread.

To vary the tension of the controller spring, loosen the set screw (U, Fig. 17), at the left of the controller, which holds the thread controller stud (V, Fig. 17), then, using a screwdriver, turn the stud (V) to the right or left, as required, and when the desired tension of the controller spring is obtained, securely tighten the set screw (U). In any case, when an unusually light tension is used, the tension on the controller spring should be correspondingly light. The coils of the controller spring should be oiled occasionally.

## To Place a New Thread Controller in Position

Loosen the set screw (U, Fig. 17) which holds the thread controller stud, and remove the thread controller from the arm, remove the tension adjusting nut (W, Fig. 17) and tension spring, withdraw the stud and replace the controller spring, taking care to slide the small tail on the coil of the spring into the notch in the stud over which the coil slides, putting the tension discs and outside rim of tension washer in between the coil and loop of the controller spring, replace the tension spring and adjusting nut on the stud and place in position on machine, then securely tighten the set screw (U).

## To Set the Needle Bar

The needle bar which is in the machine when shipped from the factory, has upon it (about two inches from the bottom) two lines  $\frac{3}{8}$  inch apart. When the needle bar is at its lowest point, set it so that its highest mark is even with the underside of the arm head.

To set a new needle bar which has no mark. Set the needle bar so that when it rises  $\frac{3}{8}$  inch from its lowest position, the point of the hook will be at the centre of the needle and about  $\frac{1}{8}$  inch above the eye.

## Hook Saddle with Mechanical Bobbin Case Stop Opening Lever

The illustration below, of the sewing hook saddle, shows the sewing hook and screw (Y, Fig. 18) 200556, passing down into

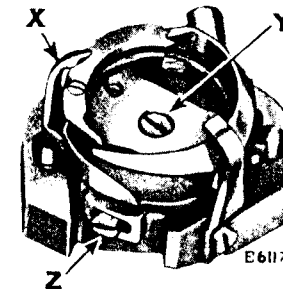

Fig. 18. View of Sewing Hook Saddle  
with the Hook Gib Closed

the gear socket, binding the sewing hook and socket together. The long beak sewing hook for leather work is also shown and the screw (Z, Fig. 18) at the left of the gear for adjusting the position of the bobbin case opening lever.

The bobbin case lever (X, Fig. 18) at the left of the hook, actuated by the bobbin case lever eccentric on the hook washer, moves the projection and turns the bobbin case slightly, making an opening between the bobbin case stop and the stop on the throat plate when the thread is across the bobbin case and passing between the stops. The bobbin case lever may be adjusted by loosening the bobbin case lever fulcrum screw (Z, Fig. 18) and moving the fulcrum forward or backward, but the fulcrum should not cause the bobbin case lever to move far enough to make a bind between the stop on the throat plate and the bobbin case lever.

#### To Adjust the Sewing Hook to and from the Needle

If the hook runs too far from or too near the needle, loosen the hook saddle screws just enough to permit the saddle to be driven with light blows to the position desired, and retighten the hook saddle screws.

#### Needle Guard

The needle guard, which is part of the hook washer, should stand out far enough to prevent the point of the hook from striking the needle, but not far enough to prevent the point of the hook from catching the loop. Bend the needle guard slightly to adjust it.

#### To Time the Sewing Hook

**To see if the sewing hook is in correct time.** Remove the cylinder end cover, slide and throat plate and turn the balance wheel toward you until the needle bar has passed its lowest position and risen so that the lower mark on it is even with the under-side of the arm head. If in correct time, the point of the hook will be at the centre of the needle and  $\frac{1}{8}$  inch above the eye; if not, loosen the screws in the bevel gear (T, Fig. 15) on the shaft under the hook and turn this gear forward or backward slightly until the hook is in time as instructed above, then retighten the screws. On very heavy work it may be necessary to set the needle bar a little lower and the hook slightly slower than the above rule.

#### To Remove the Sewing Hook from the Machine

Remove the hook gib screw at the heel of the hook and move the gib aside to allow the base of the bobbin case to be taken

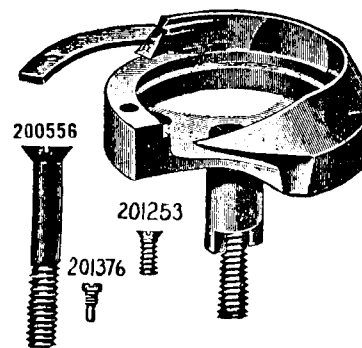

Fig. 19

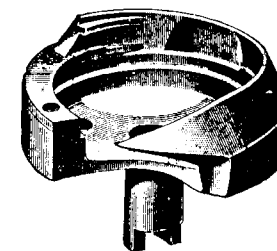

Fig. 20

out, after which remove the screw, shown in Fig. 19, from the centre of the hook. Tapping the hook lightly on the bottom of its rim will force it from its socket. Do not try to pry it out, as prying may bend the shank of the hook. In replacing the hook, be sure that the prongs of the shank properly enter the slot at the bottom of the socket, otherwise the hook will be out of time.

#### To Remove the Arm Shaft

Through the large hole (O, Fig. 13) near the presser bar, loosen the set screw and remove the check and position screws from the needle bar crank; loosen the set screw and remove the position screw from the feed driving eccentric (E, Fig. 11) and vertical shaft driving bevel gear (G, Fig. 11), take hold of the balance wheel and draw out the arm shaft.

#### To Remove the Arm Shaft Bushing (Front)

Remove the arm shaft then loosen the bushing position screw (F, Fig. 14) at the back of the arm, and after removing the needle bar, take-up cam, etc., insert a brass rod through the bushing (back) hole and drive the front bushing out.

### To Remove the Arm Shaft Bushing (Back)

Remove the three screws in the bushing flange (Q, Fig. 14) and insert a brass rod from the front and drive the bushing out.

### Needle Bar Crank and End Play of Shaft

When replacing the arm shaft bushings, see that the grooves are in line for the position screws to enter, and tighten the screws. When setting the needle bar crank be sure to replace its position screw in the hole nearest to the presser bar when the screw holes are uppermost, turn the position screw firmly into the shaft, and the check screw upon it. The end play of the upper shaft is taken up by means of the screw in the end of the shaft at the balance wheel. Place the position screw in the feed driving eccentric and tighten the set screw.

### Balance Wheel

Place the balance wheel on the shaft so that the screw nearest to you will enter the groove in the shaft.

**SINGER** Needles should be used  
in **SINGER** Machines  
These Needles and their Containers  
are marked with the  
Company's Trade Mark "SIMANCO.\*" 1

Needles in Containers marked  
"FOR SINGER MACHINES"  
are NOT **SINGER** made needles. 2