

SINGER
119W1

USE ONLY **SINGER*** OILS and LUBRICANTS

*They insure freedom from lubricating trouble and
give longer life to sewing equipment*

The following are the correct lubricants for this machine:

TYPE B—MANUFACTURING MACHINE OIL, HEAVY GRADE

When a stainless oil is desired, use:

TYPE D—MANUFACTURING MACHINE OIL, STAINLESS,
HEAVY GRADE

GEAR LUBRICANT

This specially prepared grease is recommended for gear
lubrication on manufacturing sewing machines.

OTHER **SINGER** LUBRICANTS

TYPE E—STAINLESS THREAD LUBRICANT

For lubricating the needle thread of sewing machines for
stitching fabrics or leather where a stainless thread lubri-
cant is required.

TYPE F—MOTOR OIL

For oil lubricated motors and plain bearings in power
tables and transmitters.

NOTE: All of the above oils are available in 1 quart,
1 gallon and 5 gallon cans or in 55 gallon drums.

BALL BEARING LUBRICANT

This pure grease is specially designed for the lubrication
of ball bearings and ball thrust bearings of motors and
electric transmitters, ball bearing hangers of power tables,
etc. Furnished in 1 lb. and 4 lb. tins.

Copyright, U. S. A., 1914, 1921, 1922, 1923, 1925, 1926, 1929, 1931, 1934, 1940 and 1941,
by The Singer Manufacturing Company
All Rights Reserved for all Countries

2095w

INSTRUCTIONS FOR USING AND ADJUSTING **SINGER*** SEWING MACHINE

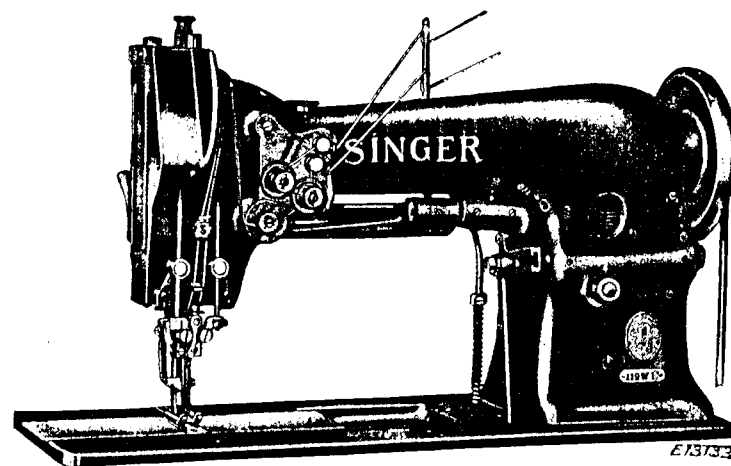

119w1

HIGH SPEED

HEMSTITCH

*A TRADE MARK OF

THE SINGER MANUFACTURING COMPANY

TO ALL WHOM IT MAY CONCERN:

The improper placing or renewal of the Trade Mark "SINGER" or any other of the Trade Marks of The Singer Manufacturing Company (all of which are duly Registered Trade Marks) on any machine that has been repaired, rebuilt, reconditioned, or altered in any way whatsoever outside a SINGER factory or an authorized SINGER agency is forbidden.

THE IMPORTANCE OF USING **SINGER*** PARTS AND NEEDLES IN **SINGER** MACHINES

The successful operation of SINGER machines can only be assured if SINGER parts and needles are used. Supplies are available at all SINGER Shops for the Manufacturing Trade, and mail orders will receive prompt attention.

SINGER Needles should be used
in SINGER Machines.
These Needles and their Containers
are marked with the
Company's Trade Mark "SIMANCO.*" 1

Needles in Containers marked
"FOR SINGER MACHINES"
are NOT **SINGER** made needles. 2

DESCRIPTION

Machine 119 w 1 is designed for hemstitching handkerchiefs, shirtwaists, sheets, pillowcases, etc., at high speed.

It has two vibrating needles and an independently driven piercer and makes the overedge hemstitch at each side of the hemstitch opening. For closely woven, stiff or heavy fabrics, a detachable auxiliary piercer is furnished with the machine. This piercer perforates the fabric in advance of the needles and enables the needles to work more freely. The auxiliary piercer is not required for fabrics which have been previously drawn.

The machine makes $\frac{1}{16}$ inch openings and has a straightaway feed which carries the fabric forward at every third stitch, as it collects the cross threads and holds them in the form of bars or spokes.

The machine has two gear driven, rotary sewing hooks.

Speed

The maximum speed recommended for Machine 119w1 is 2250 per minute, depending upon the nature of the material being sewn. The machine should be run slower than the maximum speed until the parts which are in movable contact have become glazed by their action upon each other.

When the machine is in operation the balance wheel should always turn over toward the operator.

Needles

Needles for Machine 119w1 are of Class and Variety 130x19 and are made in sizes 10, 12, 14, 16 and 18. The 130x19 needle has a stub point and if a sharp point needle is desired, orders should specify 130x27.

The size of the needle to be used should be determined by the size of the thread, which must pass freely through the eye of the needle. If rough or uneven thread is used, or if it passes with difficulty through the eye of the needle, the successful use of the machine will be interfered with.

Orders for needles must specify the **quantity** required, the **size** number, also the **class** and **variety** numbers separated by x.

The following is an example of an intelligible order:

"100 No. 14, 130x19 Needles."

The best results will be obtained in using the needles furnished by the Singer Sewing Machine Company.

Thread

Left twist thread should be used in the needles. Either right or left twist can be used in the bobbins.

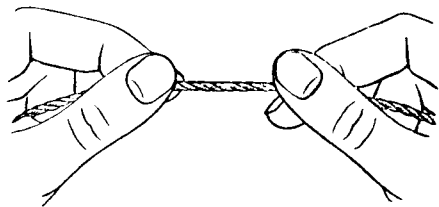

Fig. 6. How to Determine the Twist

Hold the thread as shown above. Turn the thread over toward you between the thumb and forefinger of the right hand; if left twist, the strands will wind tighter; if right twist, the strands will unwind.

Fine thread should always be used. Sizes 70 to 100 cotton thread are recommended.

To Set the Needles

Turn the balance wheel over toward you until the needle bar moves up to its highest point; loosen the set screws in the needle holder and put the needles up into the holder as far as they will go, the inside needle or the one nearest the upright part of the arm having its long groove toward the left, and the outside needle or the one farthest from the upright part of the arm having its long groove toward the right, the eyes of both needles being directly in line with the machine bed, then tighten the set screws.

Care must be taken to set the needles so that they will swing freely, with their points completely housed, in the grooves of the piercer on the inside vibration, to assure clear openings.

To Remove the Bobbins

Draw out the slide plates in the bed of the machine. Turn the balance wheel over toward you until the needle bar moves

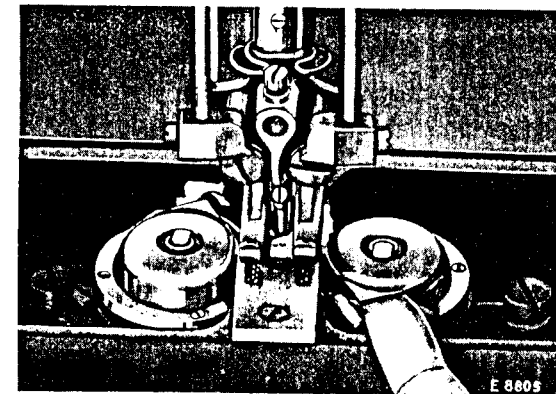

Fig. 7. Removing the Bobbin

up to its highest point. Place the thumb or finger under the projection on the side of the bobbin case cap, as shown in Fig. 7, then lift out the cap and remove the bobbin.

To Wind the Bobbin

(See Fig. 8)

Fasten the bobbin winder to the table with its driving pulley in front of the machine belt, so that the pulley will drop away from the belt when sufficient thread has been wound upon the bobbin.

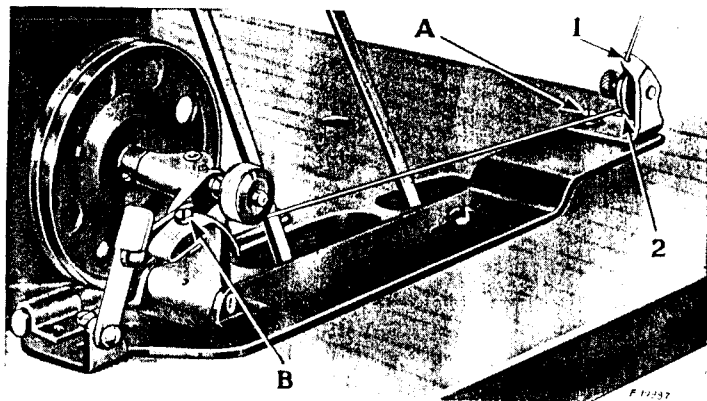

Fig. 8. Winding the Bobbin

Place the bobbin on the bobbin winder spindle and push it on as far as it will go.

Pass the thread down through the thread guide (1) in the tension bracket, around the back and between the tension discs (2). Then wind the end of the thread around the bobbin a few times, push the bobbin winder pulley over against the machine belt and start the machine.

When sufficient thread has been wound upon the bobbin, the bobbin winder will stop automatically.

If the thread does not wind evenly on the bobbin, loosen the screw (A) in the tension bracket and move the bracket to the right or left as may be required, then tighten the screw.

The amount of thread wound on the bobbin is regulated by the screw (B). To wind more thread on the bobbin, turn the screw (B) inwardly. To wind less thread on the bobbin, turn the screw outwardly.

Bobbins can be wound while the machine is stitching.

Note: When the machine is fitted with a loose pulley, the balance wheel can be released to permit the winding of bobbins without running the stitching mechanism.

To release the balance wheel, turn the thumb screw at the right of the balance wheel over toward you. It is necessary to hold the balance wheel while loosening the thumb screw. After the bobbin is wound, turn the thumb screw over from you to tighten the balance wheel.

To Thread the Bobbin Case Caps

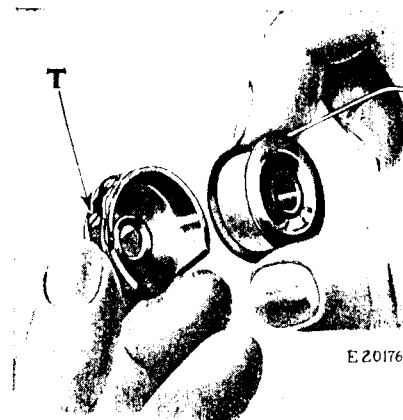

Fig. 9

Hold the bobbin between the thumb and forefinger of the right hand, as shown in Fig. 9, the thread drawing on the top from the left toward the right.

With the left hand, hold the bobbin case cap as shown in Fig. 9, the tension spring being at the left, and place the bobbin into it.

Then pull the thread into the slot (1, Fig. 10) in the edge of

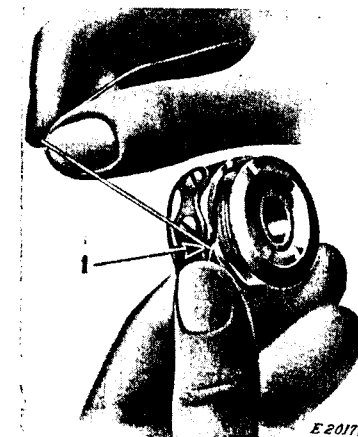

Fig. 10



Fig. 11

the bobbin case cap, draw the thread under the tension spring and into the notch in the end of the tension spring, as shown in Fig. 11.

To Replace the Bobbin Case Caps

To replace the bobbin case cap at the right of the needles, after threading, take the cap in the right hand, holding the bobbin

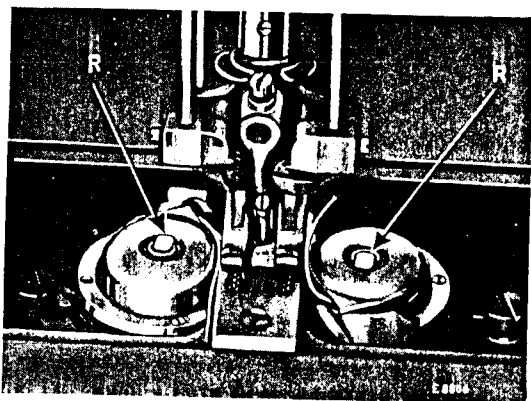

Fig. 12. Bobbin Case Caps Threaded and Replaced

in the cap with the thumb and replace it on the centre stud, then push down the latch (R, Fig. 12), having the thread under and at the left of the projection as shown in Fig. 12, and replace the slide plate.

To replace the left bobbin case cap, after threading, take the cap in the left hand, holding the bobbin in the cap with the thumb and place it on the centre stud of the left bobbin case, then push down the latch (R, Fig. 12), having the thread under and at the right of the projection as shown in Fig. 12, and replace the slide plate.

To Thread the Needles

(See Fig. 13)

To thread the outside needle or the one farthest from the upright part of the arm, pass the thread from the left spool on the spool stand, through the left guide at the top of the spool stand, down and from right to left through the hole (1) in the pin on top of the machine, then from back to front through the hole (2) in the pin, into the wire thread guide (3) at the right of the upper thread retainer, through the upper thread retainer (4), over from right to left between the left tension discs (5), down under from right to left into the thread controller (6), into the thread controller spring (7), up and from right to left

through the upper hole (8) in the end of the thread take-up lever, down through the thread guide (9), through the left side of the thread check (10), through the thread guides (11 and 12) and from right to left through the eye of the left or outside needle (13).

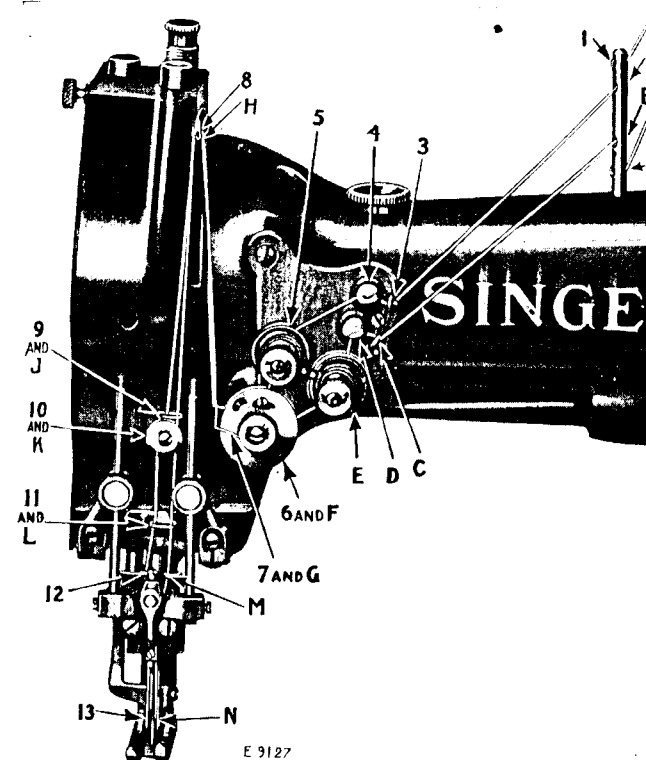

Fig. 13. Threading the Needles

To thread the inside needle or the one nearest the upright part of the arm, pass the thread from the right spool on the spool stand, through the right guide at the top of the spool stand, down and from right to left through the hole (A) in the pin on top of the machine, then up and from back to front through the hole (B) in the pin, into the wire thread guide (C) at the right of the lower thread retainer, through the lower thread retainer (D), under from right to left between the right tension discs (E), down under from right to left into the thread controller (F), into the thread controller spring (G), up and from right to left through the lower hole (H) in the end of the thread take-up lever, down through the thread guide (J), through the right side of the thread check (K), through the thread guides (L and M) and from left to right through the eye of the right or inside needle (N).

Draw about three inches of thread through the eye of each

To Prepare for Sewing

With the left hand hold the ends of the needle threads, leaving them slack from the hand to the needles. Turn the balance wheel over toward you until the needles move down and up again to their highest point, thus catching the bobbin threads; draw up the needle threads and the bobbin threads will come up with them through the holes in the throat plate. Lay the threads back under the presser foot.

To Commence Sewing

Place the material beneath the presser foot, lower the presser foot and commence to sew, turning the balance wheel over toward you.

To Regulate the Length of Stitch

The length of stitch is regulated by moving the end of the connection (G, Fig. 2) which is fastened by the hexagon nut (F, Fig. 2) in the slide on the upright part of the arm. To increase the length of stitch, loosen the hexagon nut (F) and move the connection away from you in the slide. To shorten the stitch, move the connection toward you in the slide. When the desired length of stitch has been obtained, tighten the hexagon nut (F). Care should be taken to see that the length of stitch is adjusted according to the material which is being sewn. A stitch that is too short will not leave a sufficient number of threads between the openings in fine material. If the stitches are made too close together, they may be cut by the piercer.

To Set the Piercer

When it is necessary to change the piercer, loosen the piercer set screw and remove the piercer from the piercer holder. Place the new piercer in the holder in a central position between the needles so that the points of the needles will be properly housed in the grooves of the piercer when the needles descend. When the piercer bar is at its lowest point, about $\frac{1}{8}$ inch of the curved portion of the piercer should show above the throat plate.

To Set the Auxiliary Piercer

Loosen the set screw (N2, Fig. 16) and put the auxiliary piercer up into the holder as far as it will go, then securely tighten the set screw (N2).

As the function of the auxiliary piercer is to open the fabric in advance of the piercer, it must be adjusted according to the length of stitch which is being made, so that the advance perforations made by it will be correctly entered by the piercer and needles. To make this adjustment, loosen the screw (L2, Fig. 16) and move the auxiliary piercer holder (M2, Fig. 16) forward or backward, as required, then securely tighten the screw (L2).

PIERCERS AND AUXILIARY PIERCERS

Used in Machine 119w1

ALSO DIAGRAMS SHOWING SHAPES

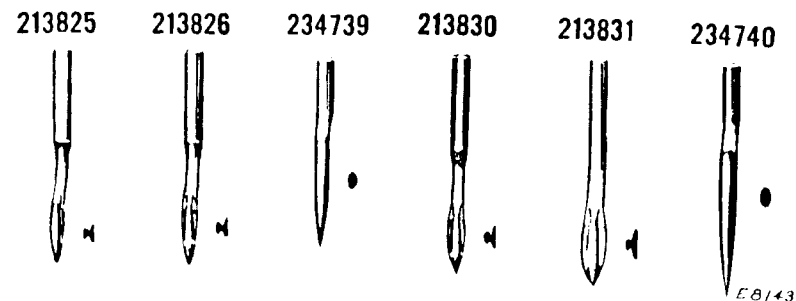

Fig. 14

The above diagrams show actual sizes and shapes of punctures

Unless otherwise ordered, this machine will be regularly fitted with Piercer 213826 and Auxiliary Piercer 234739, for ten stitches to the inch. Piercer 213825 is also included with the regular equipment for use with Auxiliary Piercer 234739, for finer stitching.

For making slightly larger openings, Piercers 213830 and 213831 and Auxiliary Piercer 234740 can be furnished in place of the regular equipment, or they can be supplied additionally at an extra charge.

Stitch Formation and Piercer Action How Straightaway Hemstitch Opening is Made

One double stitch is made on the inside vibration, another on the outside vibration and the third on the inside vibration of the needles. The piercer rises out of the material at every stitch.

First Stitch. On the inside vibration, the piercer, followed by the needles with their points housed in its grooves, enters to its widest part and spreads the material just after the feed dog has dropped below the surface of the throat plate; as the needles rise they spread a little for the hooks to catch the thread loops.

Second Stitch. On the outside vibration, the needles descend spread apart, each needle entering the material outside of and the piercer within the opening, to make the stitches which draw and hold the bar (or spoke) stitches up to the material in imitation of hand work.

Third Stitch. On the inside vibration, the piercer, followed by the needles with their points housed in its grooves, descends again into the opening for the third stitch. After the piercer and needles rise sufficiently clear of the material, the feed dog rises and moves the material forward for the needles and piercer to enter the next opening made by the auxiliary piercer. The needles and piercer then work the first stitch in the opening, binding the intervening threads of the material into a bar or spoke. Each set of three stitches for each opening is formed in the same manner.

Knee Lifter

The knee lifter is used for raising the presser foot by knee pressure against the knee plate, leaving both hands free to manipulate the work. If the knee lifter does not raise the presser foot satisfactorily, adjust the rod on the rock shaft to strike the bell crank on the underside of the bed of the machine at a point which will cause the presser foot to be lifted to the required height.

To Regulate the Tensions

The tensions on the needle threads should only be regulated when the presser foot is down, as these tensions are released and inoperative when the presser foot is raised by the lifter.

The tensions on the needle threads are regulated by the thumb nuts (E3, Fig. 21) at the front of the tension discs. To increase the tension, turn these thumb nuts over toward the right. To decrease the tension, turn the thumb nuts over toward the left.

The tensions on the bobbin threads are regulated by means of the screw (T, Fig. 9) nearest the centre of the tension spring on the outside of each bobbin case cap. To increase the tension, turn this screw over toward the right. To decrease the tension, turn the screw over toward the left.

To Turn a Square Corner

After the piercer has entered the material for what is to be the last opening in a straight line, and before the needles are down, turn the material at right angles to the last line of openings and proceed to stitch as before. There will be no extra hole punctured at the corner by the auxiliary piercer.

To Remove the Work

Let the thread take-up lever rest at its highest point, raise the presser foot and draw the work back and cut the threads close to the material.

INSTRUCTIONS FOR ADJUSTERS AND MACHINISTS

To Time the Cams

To determine whether the feed lifting cam and gear (S, Fig. 15), needle vibrating cam (V, Fig. 15) and feed driving

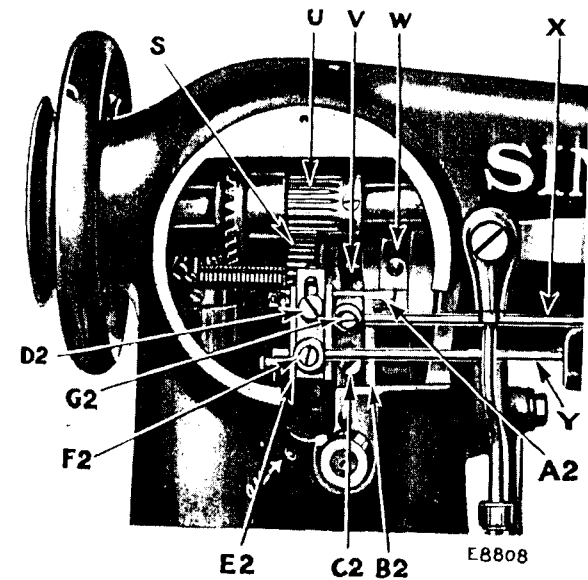

Fig. 15. Showing Timing Finger at Back of Machine For Timing Cams (S, V and W)

cam (W, Fig. 15) are correctly timed, raise the round cover plate at the rear of the machine. Turn the balance wheel over toward you until the needle bar is on its upward stroke, after having completed the stitch on the hem, and the lower timing mark (K2, Fig. 16) on the needle bar is just visible at the lower end of the needle bar bushing. When the needle bar is in this position, the horizontal marks on the needle vibrating cam (V) and feed driving cam (W) and the line on the side of the ground-off tooth of the feed lifting cam and gear (S) should be in line with each other and register at the top end of the needle vibrating lever (A2, Fig. 15). A slight deviation may then be made to obtain the results desired.

It is necessary that the timing marks on the three cams (S, V and W) should always be in line with each other. If

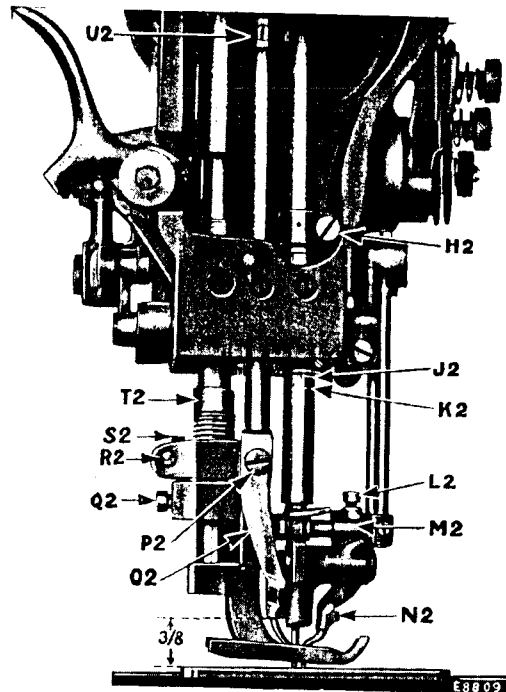

Fig. 16. Showing Upper Timing Mark on Needle Bar Centred with Lower End of Needle Bar Bushing at (J2)

they are not, loosen the two set screws in each of the cams (V and W) and turn the cams until the horizontal lines marked on them register with the line on the side of the ground-off tooth of the feed lifting cam and gear (S); then firmly tighten the set screws.

In case the cams (S, V and W) are in time with each other, but not in time with the needle bar, loosen the two set screws in the small gear (U, Fig. 15) and turn the feed lifting cam and gear (S) until the lines on the cams (V and W) register with the end of the timing finger (A2), then tighten the two set screws. When making this adjustment, be sure to have the lower timing mark (K2, Fig. 16) on the needle bar just visible at the lower end of the needle bar bushing, when the needle bar is on its upward stroke after having completed the stitch on the hem.

To Set the Needle Bar at the Correct Height

Turn the balance wheel over toward you until the needle bar moves down to its lowest point. When the needle bar is in this position, the upper timing mark (J2, Fig. 16) on the needle bar should be just visible at the lower end of the needle bar bushing.

In case the needle bar is not set at the correct height, loosen the pinch screw (H2, Fig. 16) in the needle bar connecting stud and move the needle bar up or down until it is at the correct height, as instructed above, then firmly tighten the screw (H2) in the needle bar connecting stud.

To Time the Sewing Hooks

To determine whether the hooks are correctly timed, turn the balance wheel over toward you until the lower timing mark (K2, Fig. 16) on the needle bar is just visible at the lower end of the needle bar bushing, when the needle bar is on its upward stroke. When the needle bar is in this position, the points of the hooks should be at the centre of the needles.

In case the hooks are not correctly timed, loosen the two set screws in the hook gears (L and M, Fig. 5) on the underside of the machine and turn the hooks until they are in the correct position, as instructed above; then firmly tighten the two set screws in the gears (L and M).

To Set a Needle Bar which has no Mark

Set the needle bar so that when it rises $\frac{3}{4}$ inch from its lowest position, the points of the hooks will be at the centre of the needle blades and about $\frac{1}{4}$ inch above the eyes. By looking across the top of the bobbin case, down to the eyes of the needles, the full length of the eyes should be seen below and close up to the points of the hooks.

To Set the Sewing Hooks To or From the Needles

To prevent the points of the sewing hooks from dividing the strands of the threads, they should run as close to the needles (within the scarf) as possible.

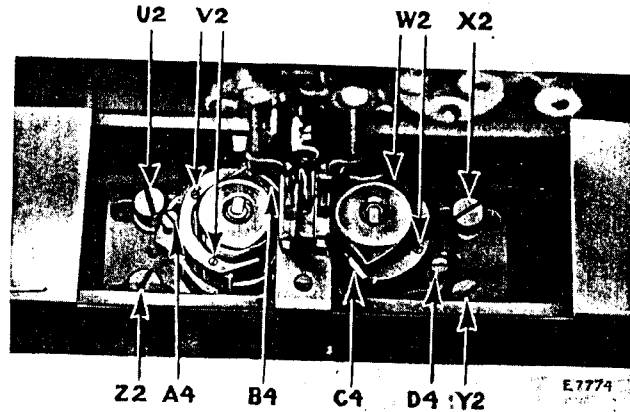

Fig. 17. Adjustment of Hook Saddles
Also Adjustment of Mechanical Opener

Turn the balance wheel over toward you until the points of the sewing hooks are at the centre of the needles. If the sewing hooks run too far from or too close to the needles, loosen the four screws (U2, X2, Y2 and Z2, Fig. 17) underneath the bed of the machine and move the hook saddles to the right or left, as may be required, until the points of the hooks are as close to the needles as possible without striking them, then securely tighten the four screws (U2, X2, Y2 and Z2).

To Remove the Bobbin Case Bases from the Sewing Hooks

Remove the four hook gib screws (V2 and W2, Fig. 17) from the sewing hooks, lift off the hook gibs and remove the bobbin case bases.

To Remove the Sewing Hooks from the Machine

Remove the throat plate and feed dog. Also remove the bobbin case bases as instructed above, then loosen the screws in the hook shaft gears (L and M, Fig. 5) and lift out the sewing hooks.

To Adjust the Mechanical Openers

The bobbin case levers (B4 and C4, Fig. 17), actuated by the eccentric on the hook washer, strike the projection on the bobbin case and turn the bobbin case slightly, making an opening between the bobbin case stop and the stop on the throat plate when the thread is across the bobbin case and passing between the stops.

The bobbin case levers (B4 and C4) may be adjusted by loosening the bobbin case lever fulcrum screws (A4 and D4, Fig. 17) and moving the fulcrum forward or backward.

This adjustment should be made so that the opening between the lever and the edge of the bobbin case is just perceptible when the bobbin case lever has opened the bobbin case all the way.

Needle Guard

The function of the hook washer (AA, Fig. 18), which is attached to the bottom of each sewing hook, is to prevent the

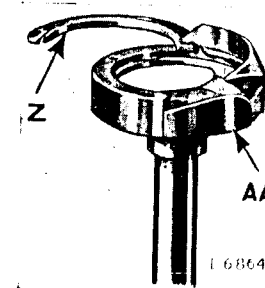

Fig. 18. Sewing Hook Removed from Machine,
Showing Hook Washer

point of the hook from striking the needle, if, when passing through the material, the needle is deflected towards the hook.

The upright portion of the hook washer should be sprung with a screwdriver or other instrument until it prevents the hook point from striking the needle; it should not however be sprung outwardly enough to deflect the needle from its normal path.

Needle Vibrating Mechanism

The needle vibrating mechanism is operated by the gear (U, Fig. 15) which drives the needle vibrating cam (V, Fig. 15) which in turn actuates the needle vibrating lever to which are attached the connections (B2 and E2, Fig. 15). The vibrating motion is transmitted from the needle vibrating lever to the needle holders (N3 and O3, Fig. 20) by means of the connections (B2 and E2, Fig. 15), the pitmans (X and Y, Fig. 19), the bell cranks (J3, Fig. 19), the links (I13, Fig. 19), the cranks (L3 and Q3, Fig. 20) and the rods (K3 and R3, Fig. 20), causing the spreading and drawing in action of the needles.

On the outside vibration of the needles, the pitmans (X and Y, Fig. 19) draw the needle vibrating rods (K3 and R3, Fig. 20) toward each other, by their connection with the needle holders (N3 and O3, Fig. 20). On the inside vibration of the needles, the pitmans (X and Y) spread the needle vibrating rods (K3 and R3).

When the needles are on their descending inside vibration, the eyes of the needles should be level with the material before

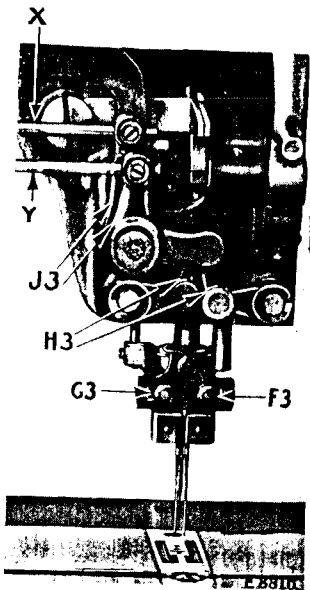

Fig. 19. Needle Vibrating Mechanism at Back of the Machine

the needles commence their outward movement toward the sewing hooks. This will bring the strain upon the shanks of the expanding needles when the needle bar has reached the lowest point of its downward stroke.

As the needle vibrating pitmans (X and Y, Fig. 15) are independently mounted, they must be separately adjusted.

The lower pitman (Y, Fig. 15) controls the vibrations of the left or outside needle. To make the left needle vibrate farther to the left over the edge of the material, loosen the screw (F2, Fig. 15) and lengthen the lower pitman (Y), then securely tighten the screw (F2).

The upper pitman (X, Fig. 15) controls the vibrations of the right or inside needle. To make the inside needle vibrate farther to the right over the edge of the material, loosen the screw (G2, Fig. 15) and lengthen the upper pitman (X), then securely tighten the screw (G2).

Either needle can be set closer to or farther from the other by loosening the nuts (F3 and G3, Fig. 19) and moving the needle holders (N3 and O3, Fig. 20) as required, then securely tighten the nuts (F3 and G3).

To Change the Bight or Vibration of the Needles

The width of bight or extent of the lateral vibration of the needles is regulated by raising or lowering the needle vibrating connections (B2 and E2, Fig. 15) which are fastened by the screws (C2 and D2, Fig. 15).

For a narrow bight of the left or outside needle, loosen the screw (D2) and lower the needle vibrating lever (E2); for a wider bight, raise the lever (E2), then securely tighten the screw (D2).

For a narrow bight of the right or inside needle, loosen the screw (C2) and lower the needle vibrating lever (B2); for a wider bight, raise the lever (B2), then securely tighten the screw (C2).

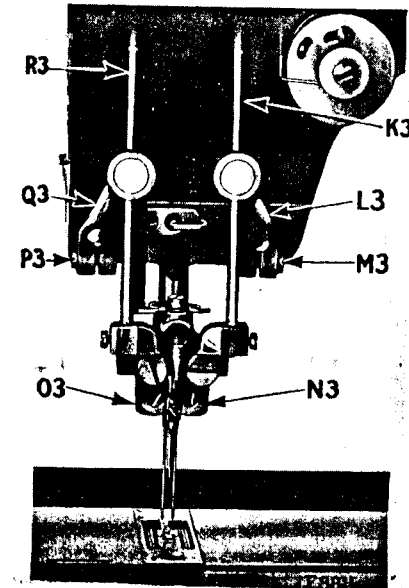

Fig. 20. Needle Vibrating Mechanism at Front of the Machine

When the needles are on their descending inside vibration, the points of the needles should be properly housed in the grooves of the piercer. If the points of the needles appear outside of the grooves of the piercer on the descending inside vibration, a very fine adjustment may be made by loosening the two screws (M3 and P3, Fig. 20) and swinging the needle vibrating cranks (L3 and Q3, Fig. 20) to the right or left, as may be required, after which securely tighten the two screws (M3 and P3).

Thread Controller

The function of the thread controller spring is to hold back the slack of the needle threads until the eye of each needle nearly reaches the goods in its descent, as without this controlling action of the spring, the slack thread or silk (more especially silk) will sometimes be penetrated by the point of the needle as the needle is descending.

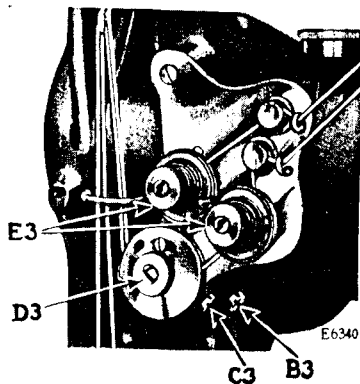

Fig. 21. Adjustment of Thread Controller

To change the thread controller stop for more controller action on the threads, loosen the set screw (C3, Fig. 21) and turn the thread controller spring stop to the right; for less action, turn the thread controller spring stop to the left, after which securely tighten the set screw (C3).

It may be found advisable to increase the tension of the spring for coarse thread, or to lessen it for fine thread.

To increase the tension of the thread controller on the threads, loosen the tension stud set screw (B3, Fig. 21), located nearly under the tension stud, and turn the tension stud (D3, Fig. 21) slightly to the left with a screwdriver, or to decrease the tension, turn it to the right and retighten the stud set screw (B3).

To Adjust the Feed Dog

The feed dog should rise and show a full tooth above the throat plate when the eyes of the needles are level with the throat plate, on the upward stroke of the needle bar, after forming the third stitch in the opening. The feed dog should not begin to move forward for the next opening until the points of the needles are clear of the fabric.

To Raise or Lower the Feed Dog

Clean the lint and dirt from the feed dog. Tip the machine back on its hinges and turn the balance wheel over toward you until the feed dog is at its highest position, then loosen the pinch screw (P, Fig. 5) and adjust the feed dog as required, then securely tighten the pinch screw (P).

To Adjust the Piercer Bar

When the piercer bar is at its lowest point, the bottom end of the piercer holder (O2, Fig. 16) should be $\frac{3}{8}$ inch above the throat plate, as shown in Fig. 16. The piercer bar can be set at the required height after loosening the set screws shown at U2 in Fig. 16. The piercer must not enter the fabric before the feed dog finishes its forward movement, otherwise clear openings cannot be made.

To Time the Piercer in Relation to the Needles

To change the time of the piercer in relation to the needles, turn the eccentric shown at S3 in Fig. 3, on the arm shaft for an earlier or later movement of the piercer.

To Adjust the Hemstitch Presser Foot

There is usually but one thickness of fabric under the outside (shire side) foot plate, while there are several thicknesses under the inside (hem side) foot plate.

To set the outside foot plate lower than the inside foot plate, loosen the pinch screw (R2, Fig. 16) and turn the upright screw (S2, Fig. 16) outwardly, then tighten the pinch screw (R2). The pressure of the foot plate on the material should be only heavy enough to enable the feed to move the work along evenly regardless of variations in the thickness of the fabric to be hemstitched.

To increase the pressure of the outside foot plate on the material, loosen the set screw in the collar (T2, Fig. 16) and lower the collar to compress the spring, then tighten the set screw. For less pressure, raise the collar.

To increase the pressure of the inside foot plate on the material, loosen the lock screw (J, Fig. 4) at the back of the machine and turn down the thumb screw (H, Fig. 4) at the top of the machine. To decrease the pressure, turn up the thumb screw (H). When the desired pressure is obtained, securely tighten the lock screw (J).

Flat work requires an even pressure of the foot plates on the material.

INSTRUCTIONS FOR ATTACHING
SINGER* PICOT EDGE CUTTING
 ATTACHMENT 247650

This device will be furnished, on order, at an additional charge to the machine.

When using the Picot Edge Cutting Attachment, the best results are obtained when the machine is fitted with piercer 213830.

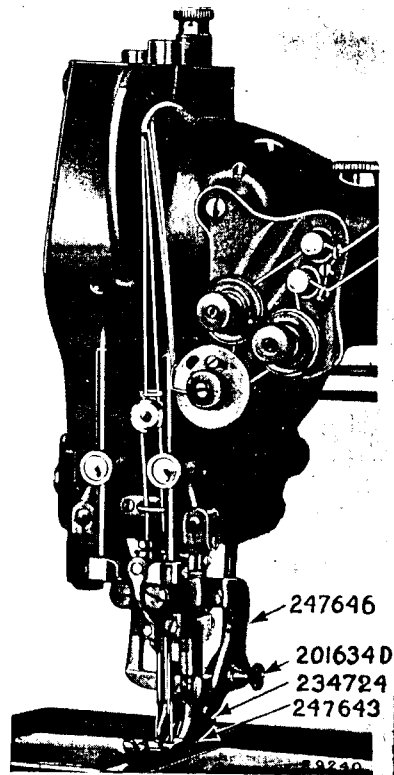
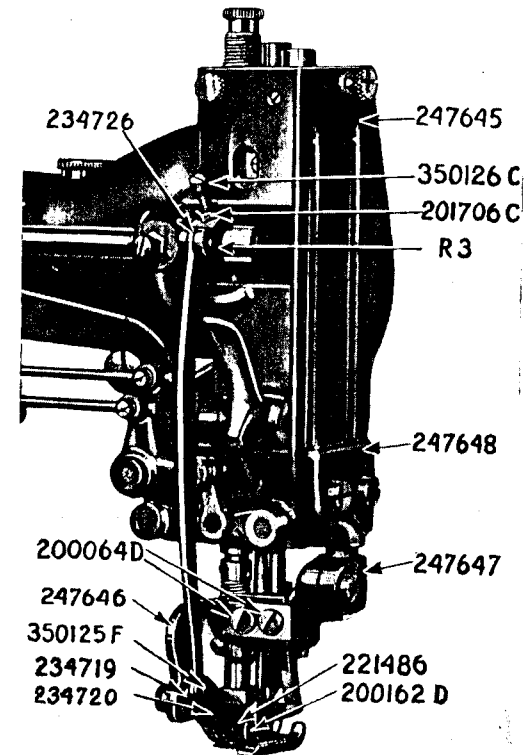

Fig. 22

1. Remove the regular presser foot from the machine and fasten presser foot 247643 in position on the machine as shown in Fig. 22. Substitute face plate 247645 for the regular face plate and fasten bracket support 247648 to the machine by means of the two screws, as shown in Fig. 23.

2. Adjust the machine, test it, set to the length of stitch desired and be sure that it is in proper sewing condition.
3. Place picot edge cutting blade arm bracket 247647, Fig. 23, in position on bracket support 247648, Fig. 23.



T. 8813

Fig. 23

4. Turn the balance wheel until the piercer is at its highest point and the feed dog is below the throat plate, and have the presser foot rest on the throat plate.
5. Place the attachment (with thumb nut 201634D, Fig. 22, at the back end of slot) in position by inserting the knives in between the presser foot shoes, and fasten the attachment on the arm bracket 247647, Fig. 23, with the two screws 200064D, Fig. 23.
6. Loosen the pinch screw in the arm bracket and raise the attachment on the bracket support until the centre of the knife fulcrum stud 234724, Fig. 22, is $\frac{7}{16}$ inch above the top of the throat plate. Place a scale or straight edge across attachment

arm 247646, Fig. 23, from front to back, and line up parallel with the presser foot, the cutting edges of the knives to be in line with the centre of the piercer, then tighten the pinch screw.

7. Remove the set screw in the rock shaft collar (R3, Fig. 23).

8. Place the operating lever 234726, Fig. 23, in position on the rock shaft collar (R3), using screw 350126c, Fig. 23, and check nut 201706c, Fig. 23, in place of set screw to hold the lever and rock shaft collar in position.

9. Raise the operating lever until the point of the upper knife blade lightly touches the throat plate, holding the lever with the left hand, turn the balance wheel with the right hand until the piercer reaches its lowest position.

(**Caution:** If the piercer touches the knife blades before reaching the lowest position, it will be necessary to raise it sufficiently to clear both knife blades; this will not interfere with the quality of hemstitching. See page 25 for adjusting the piercer bar.)

10. Fasten the operating lever with the screw 350126c and nut 201706c, using care to have the point of upper knife blade 234720, Fig. 23, just above the throat plate.

(**Caution:** If the knife is set too low, the point of the knife will be broken by striking the throat plate.)

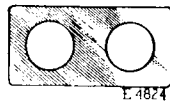

Fig. 24

11. Loosen the thumb nut 201634b, Fig. 22, and pull it forward until the point of the lower knife blade 234719, Fig. 23, rests on the throat plate, then tighten the thumb nut. The point of the knife should be just back of the needle hole.

The position of the knives back of the needles is very important as they should cut the second bar only, in order to make small curves and turn square corners.

The knives should not cut into the first bar back of the needles as this bar is required to hold the fabric in forming the

hemstitch. If the knives cut into the first bar, which may occur when using a long stitch, there are two shims 234735 (Fig. 24) which have been provided to insert between 247646 and 247647 (Fig. 23) to position the knives further back so that they will cut the second bar only.

(**Caution:** Be sure that the point of the lower knife touches the top of the throat plate, otherwise part of the fabric may pass between the knife and throat plate and some be cut and some of it torn, resulting in ragged and unsatisfactory work.)

12. Make a careful inspection to see that all parts are in position as described, test screws and nuts and see that they are properly tightened. If found correct and you have the attachment in proper position, you are now ready to operate.

(**Caution:** More care will have to be exercised by the operator when using a hemstitch machine fitted with a picot edge cutting attachment than on hemstitching alone.)

Before using this attachment on a garment, the operator should try it out on scrap material, operating the machine at slow speed until thoroughly familiar with it.

Special care should be exercised in respect to the bobbins, so that they are not allowed to run out. In view of the fact that the hemstitch feeds only every third stitch, the machine can be easily stopped when a thread breaks, without cutting more than one bar, and this is easily repaired by going over the unstitched place, using underneath a small piece of the same material.

13. When it is desired to do straight hemstitching with the attachment in place, loosen thumb nut 201634b, Fig. 22, and push it to the back end of the slot, then tighten it. This will raise the lower knife so as to permit the fabric to pass under it.

Instructions for Making Square Corners and Curves

A square corner is easily made in the following manner:

1. When the piercer is descending after the feeding operation takes place, the two needles are brought close to the piercer.
2. Allow the piercer to enter the fabric.
3. Raise the presser foot and using the piercer as a pivot, turn the fabric to a right angle.
4. Turn the material which lies back of the presser foot over away from presser foot and knives.
5. Lower presser foot and with forefingers on material at each side of presser foot even with the needles and thumbs in front of and slightly to side of presser foot, spread the material out flat.
6. Start the machine slowly for a few stitches, aiding the feeding of material with the hands just enough to bring the corner out back of the presser foot, so that the fabric on both sides of the knives can be grasped by forefinger and thumb of one hand to gently pull the material in aiding the feed, as is customary in hemstitching.

If the foregoing instructions are followed carefully, clean cut corners will be made without cutting or breaking the threads, or injuring the fabric.

To make curves, hold the fabric flat with thumbs and forefingers of both hands, turning the fabric carefully with the hands during the feeding operation, taking care to not turn it too far at any one time. The knives cut the second bar back of the needles, which permits making quite small curves. With a little practice, the operator will find this easy to accomplish.

To Remove the Knife Blades for Sharpening

Remove the cap screw 200162b, Fig. 23, together with spring 221486, Fig. 23, and hinge screw 350125F, Fig. 23, push back the knife blade hinge stud 234724, Fig. 22, both knife blades can then be easily removed or replaced.

Instructions for Sharpening Knives of Picot Edge Cutting Attachment 247650

When using Picot Edge Cutting Attachment 247650, the best results are obtained when the knives are sharpened on Knife Grinder 234746.

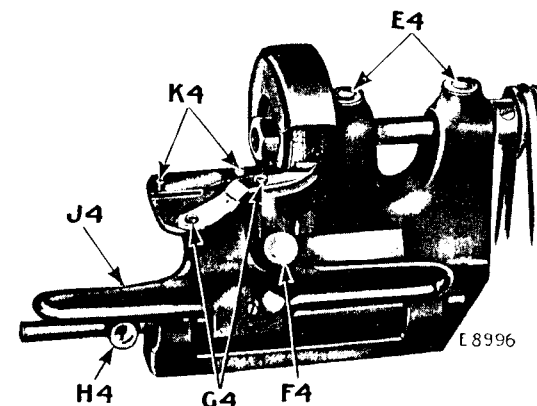

Fig. 25. Knife Grinder 234746

The grinder should be set so that the top of the emery wheel turns over toward the operator at about 3000 revolutions per minute.

To Sharpen Lower Knife 234719, place it in position on the two rear pins (K4, Fig. 25). Loosen the lock screw (H4, Fig. 25) and move the knife carrier (J4, Fig. 25) until the left edge of the blade is in line with the left edge of the grinding wheel. Then move the lock screw (H4) to the right until it bears against the casting and securely tighten the lock screw (H4). (The setting of the lock screw (H4) is important, as it prevents the body of the lower knife from being ground. After the lock screw has been once properly set, it is not necessary to change its position when sharpening either knife). Turn the adjusting screw (F4, Fig. 25) in or out until the knife bears lightly against the grinding wheel. Start the grinder and with the forefinger of the left hand pressing lightly on the knife between the pins, sharpen the full length of the cutting edge of the knife by moving the knife carrier (J4) from side to side. The least possible amount ground off is usually sufficient.

To Sharpen Upper Knife 234720, place it in position on the two pins (G4, Fig. 25). Set the adjusting screw (F4) and sharpen the blade as instructed above for the lower knife.

Caution: The knives should barely graze the emery wheel. If the knives are held with too much pressure against the emery wheel, the temper of the knives may be drawn until they are too soft for use.

Lubrication: Oil should be regularly applied to the two ball oilers (E4, Fig. 25).