

SINGER

152W1,W2

USE ONLY
SINGER
 "OIL FOR HIGH SPEED SEWING MACHINES
 (Cloth and Leather)"
 for general use
 or
 "STAINLESS OIL
 FOR HIGH SPEED SEWING MACHINES"
 where a stainless oil is desired.

These specially prepared oils are the result of extensive research. They insure freedom from lubricating trouble and give longer life to sewing machines.

THE IMPORTANCE OF USING SINGER NEEDLES FOR SEWING MACHINES

The best stitching results will be obtained by using the needles furnished by the Singer Sewing Machine Company.

Singer Needles can be purchased from any Singer Shop for the Manufacturing Trade.

Genuine Singer Needles should be used
 in Singer Machines.
 These Needles and their Containers
 are marked with the
 Company's Trade Mark "SIMANCO." 1

Needles in Containers marked
 "For Singer Machines"
 are not Singer made needles. 2

Copyright, U. S. A., 1914, 1915, 1916, 1924, 1926, 1935, 1936 and 1937,
 by The Singer Manufacturing Co.
 All Rights Reserved for all Countries

INSTRUCTIONS FOR USING AND ADJUSTING SINGER SEWING MACHINES

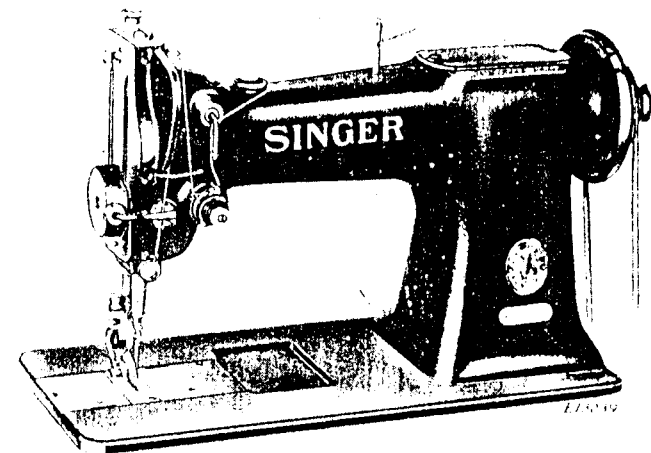

152w1 and 152w2

SINGLE NEEDLE LOCK STITCH
 FOR LEATHER

THE SINGER MANUFACTURING CO.

To all whom it may concern:

The placing or renewal of the name "Singer" (Reg. U. S. Pat. Off.) or any of the trade marks of The Singer Manufacturing Company on any machine that has been repaired, rebuilt, reconditioned or altered in any way whatsoever outside a Singer factory or an authorized Singer agency is forbidden.

Purchasing of Parts and Needles

Supplies of parts and needles for Singer machines can be purchased at any Singer Shop for the Manufacturing Trade or ordered by mail. If orders are sent by mail, money or a post office order covering their value, including postage, should be enclosed and the order will then be promptly filled and forwarded by mail or express.

Genuine Singer Needles should be used
in Singer Machines.
These Needles and their Containers
are marked with the
Company's Trade Mark "SIMANCO." 1

Needles in Containers marked
"For Singer Machines"
are not Singer made needles. 2

DESCRIPTION

MACHINE 152W1 is a single needle, short arm, lock stitch machine used for light leather work. The vertical hook is belt driven. The machine has a drop feed and a roller presser having a 3/16" lift.

MACHINE 152W2 is similar to Machine 152W1 except that it is designed for work in medium weight leather.

Speed

The maximum speed for these machines is 3000 R.P.M., depending on the nature of the material being sewn. The machines should be run slower than the maximum speed until the parts which are in movable contact have become glazed by their action on each other. When the machines are in operation, the balance wheel turns over toward the operator.

Needles

Needles for Machines 152W1 and 152W2 are of Class and Variety 16x246 and are made in sizes 9, 10, 11, 12 and 13.

The size of the needle to be used should be determined by the size of the thread which must pass freely through the eye of the needle. If rough or uneven thread is used or if it passes with difficulty through the eye of the needle, the successful use of the machine will be interfered with.

Orders for needles must specify the quantity required, the size number, also the class and variety numbers separated by the letter x.

The following is an example of an intelligible order:

"50 No. 9, 16x246 Needles,
50 No. 12, 16x246 Needles."

The best results will be obtained when using the needles furnished by the Singer Sewing Machine Company.

To Oil the Machine

When the machine is received from the factory, it should be thoroughly cleaned and oiled, and when in continuous use it should be oiled at least twice each day.

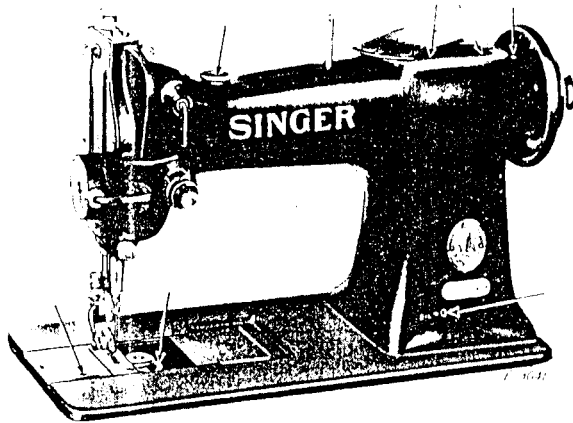

Fig. 2. Oiling Points at Front of Machine

Oil should be applied at each of the places indicated by arrows in Figs. 2, 3, 4 and 5.

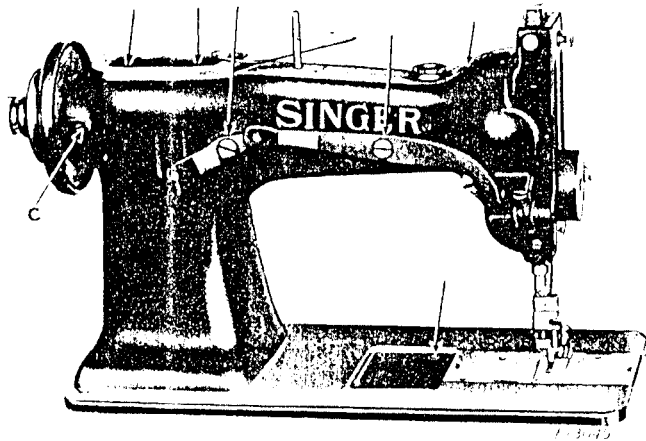

Fig. 3. Oiling Points at Rear of Machine

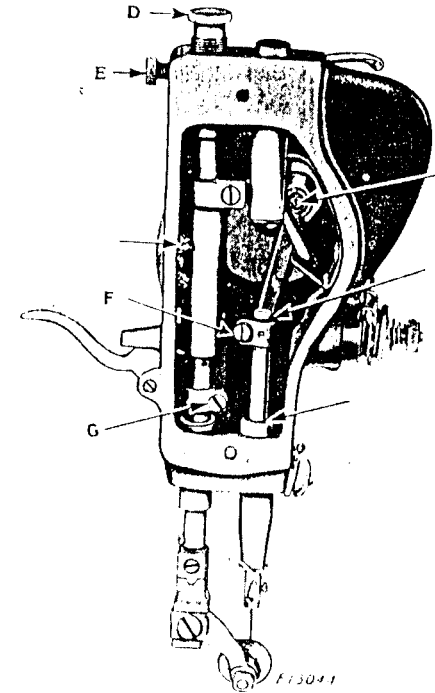

Fig. 4. Oiling Points and Adjustments Behind Face Plate

Swing back the cover at the top of the machine and swing up the face plate as shown in Figs. 2 and 4, and apply oil to the bearings thus uncovered. Turn the machine back on its hinges to reach the points underneath the bed as shown in Fig. 5.

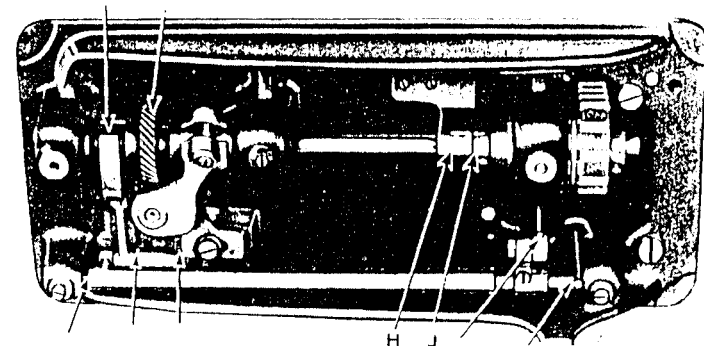

Fig. 5. Oiling Points and Adjustments Underneath the Bed

Thread

Use left twist thread for both needles. Either left or right twist thread may be used for the bobbins.

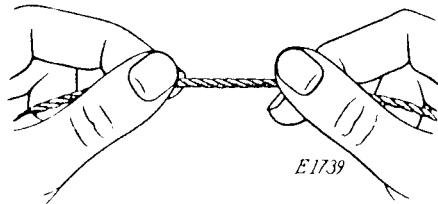

Fig. 6. How to Determine the Twist

Hold the thread as shown above. Turn the thread over toward you between the thumb and the forefinger of the right hand; if left twist, the strands will wind tighter; if right twist, the strands will unwind.

To Set the Needle

Turn the balance wheel over toward you until the needle bar moves up to its highest point; loosen the set screw in the lower end of the needle bar and put the needle up into the bar as far as it will go, with the long groove of the needle toward the left and the eye directly in line with the arm of the machine, then tighten the set screw.

To Remove the Bobbin

Draw out the slide plate in the bed of the machine. Turn the balance wheel to bring the needle to its highest position. Insert a finger under the projection (K, Fig. 7) on the side of the bobbin case cap, lift out the cap and remove the bobbin.

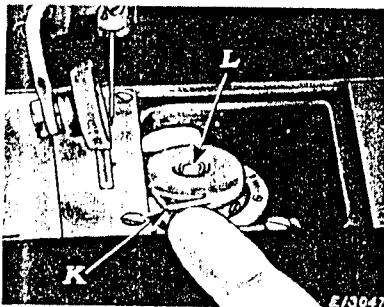

Fig. 7.

To Wind the Bobbin

Fasten the bobbin winder to the table with its driving pulley in front of the machine belt, so that the pulley will drop away from the belt when sufficient thread has been wound upon the bobbin.

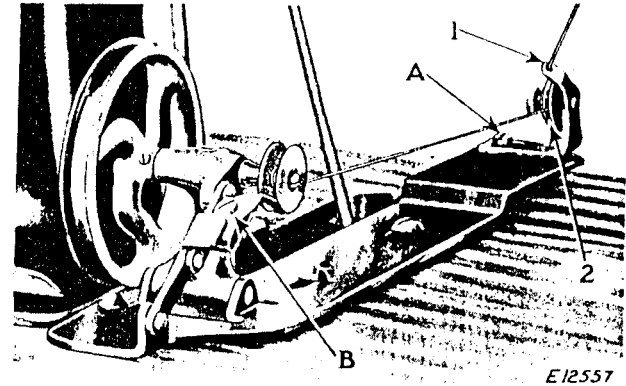

Fig. 8. Winding the Bobbin

Place the bobbin on the bobbin winder spindle and push it on as far as it will go.

Pass the thread down through the thread guide (1) in the tension bracket, around the back and between the tension discs (2). Then wind the end of the thread around the bobbin a few times, push the bobbin winder pulley over against the machine belt and start the machine.

When sufficient thread has been wound upon the bobbin, the bobbin winder will stop automatically.

If the thread does not wind evenly on the bobbin, loosen the screw (A) in the tension bracket and move the bracket to the right or left as may be required, then tighten the screw.

The amount of thread wound on the bobbin is regulated by the screw (B). To wind more thread on the bobbin, turn the screw (B) inwardly. To wind less thread on the bobbin, turn the screw outwardly.

Bobbins can be wound while the machine is stitching.

To Thread the Bobbin Case Cap

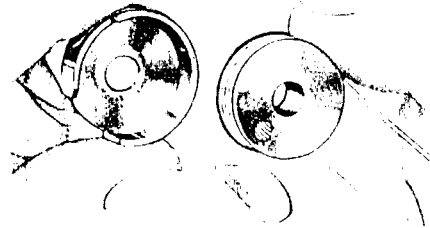

E13139

Fig. 9.

Hold the bobbin between the thumb and forefinger of the right hand, with the thread drawing off the top toward the right, as shown in Fig. 9.

Hold the bobbin case cap in the left hand as in Fig. 9, and place the bobbin into it.

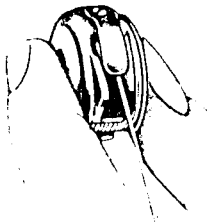

E13137

Fig. 11.

Then pull the thread into the slot in the edge of the cap as shown in Fig. 10, and down under the tension spring as in Fig. 11. Draw the thread back and forth once or twice to remove any lint which may be lodged under the spring.

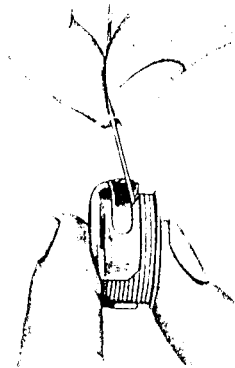

Fig. 10.

To Replace the Bobbin Case Cap

Take the cap in the right hand, holding the bobbin in the cap with the thumb, and place it on the center stud of the bobbin case base, having the thread at the left of the projection (K, Fig. 7). Then push down the latch (L) and replace the slide plate.

To Thread the Needle

Pass the thread from the unwinder, from back to front through the lower hole (1) in the pin on top of the machine, and

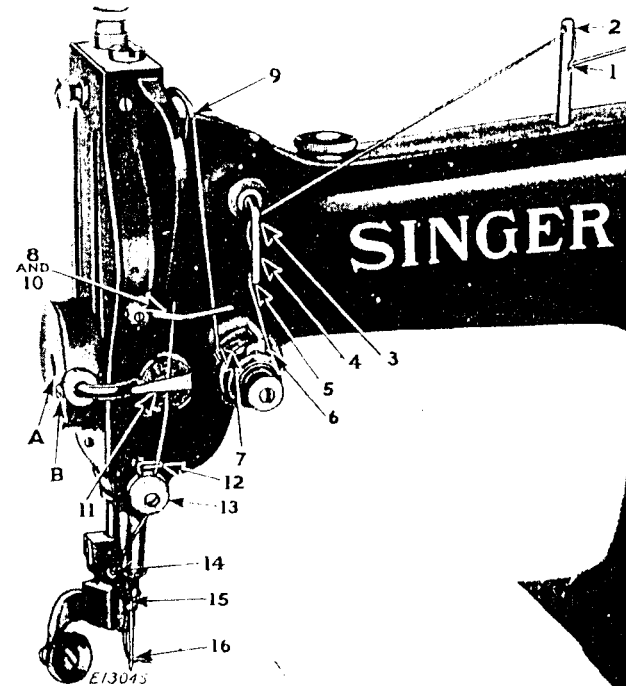

Fig. 12.

from right to left through the top hole (2), over and to the left through the upper hole (3), to the right through the middle hole (4) and to the left through the bottom hole (5) in the thread guide at the front of the machine, down to the right and around between the tension discs (6), and up against the pressure of the controller spring into the notch (7), up through the thread guide (8), to the left through the hole (9) in the take-up lever, down again through guide (10), under the finger (11) on the thread lubricator pad, down into guide (12) and to the right into thread retainer (13), down into guide (14), through the hole in the lower end of the needle bar (15), and from left to right through the eye of the needle (16). Draw about three inches of thread through the eye of the needle.

Roller Presser

For convenience in threading, press down on the roller and swing it out to the left.

To Prepare for Sewing

With the left hand hold the end of the needle thread, leaving it slack from the hand to the needle. Turn the balance wheel over toward you until the needle moves down and up again to its highest point, thus catching the bobbin thread; draw up the needle thread and the bobbin thread will come up with it through the hole in the throat plate. Lay the threads back under the roller presser and close the slide.

To Commence Sewing

Place the material beneath the roller presser, lower the presser bar and commence to sew, turning the balance wheel over toward you.

To Remove the Work

Have the thread take-up lever at the highest point, raise the roller presser, draw the work back and cut the threads close to the goods. Lay the ends of the threads back under the roller presser.

Tensions

The needle and bobbin threads should be locked in the center of the thickness of the material, thus:



Fig. 13. Perfect Stitch

If the tension on the needle thread is too tight, or if that on the bobbin thread is too loose, the needle thread will lie straight along the upper surface of the material, thus:

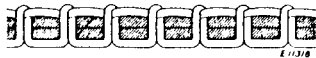

Fig. 14. Tight Needle Thread Tension

If the tension on the bobbin thread is too tight, or if that on the needle thread is too loose, the bobbin thread will lie straight along the under side of the material, thus:



Fig. 15. Loose Needle Thread Tension

To Regulate the Tensions

The tension on the needle thread is regulated by the thumb nut (N, Fig. 17) at the front of the tension discs on the front of the machine. To increase the tension, turn this thumb nut over to the right. To decrease the tension, turn this thumb nut over to the left.

The tension on the bobbin thread is regulated by means of the screw nearest the center of the tension spring on the outside of the bobbin case. To increase the tension, turn this screw over to the right. To decrease the tension, turn this screw over to the left.

To Regulate the Pressure on Material

The pressure of the roller presser on the material should be only heavy enough to enable the feed to move the work along evenly.

To change the pressure, loosen the lock screw (E, Fig. 4) at the back of the machine and turn the thumb screw (D, Fig. 4) downward for more pressure or upward for less pressure, then tighten the lock screw (E).

The Thread Lubricator

To insure satisfactory results, Singer Thread Lubricant should be used in the thread lubricator which is attached to the face plate. When replenishing the lubricant supply, fill the reservoir to about 1/8 inch below the filler hole (A, Fig. 12).

The amount of lubrication of the thread is controlled by loosening the clamp screw (B, Fig. 12) and raising or lowering the felt pad holder (11) above or below the level of the lubricant.

To Regulate the Length of Stitch

The length of stitch is regulated by the thumb screw (A, Fig. 16) at the right of the balance wheel.

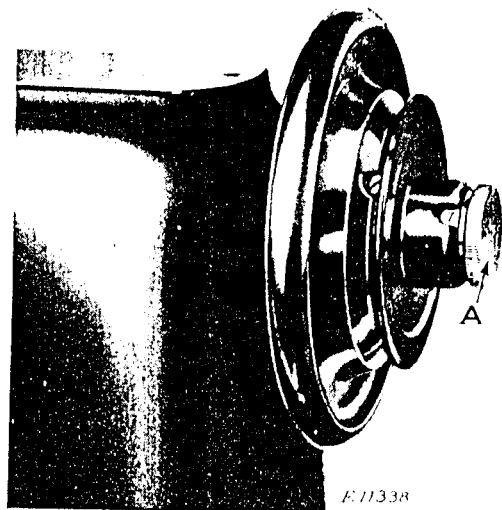

Fig. 16. Stitch Regulator

There is a notch in the hub of the balance wheel, as shown in Fig. 16, and the number appearing in the notch shows the number of stitches to the inch that the machine is ready to make.

To lengthen the stitch, turn the thumb screw (A) over toward you. To shorten the stitch, turn this thumb screw over from you.

INSTRUCTIONS FOR ADJUSTERS AND MACHINISTS

To Adjust the Thread Controller

The function of the thread controller spring is to assist the needle thread in passing over the bobbin case.

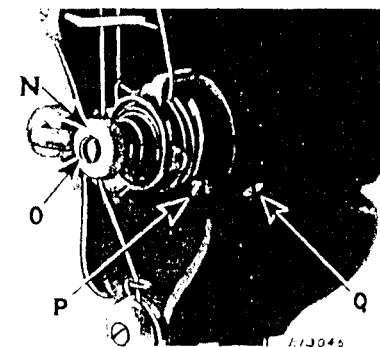

Fig. 17. Adjustment of the Thread Controller

For more controller action on the thread, loosen the set screw (P, Fig. 17) and set the thread controller spring stop lower. For less action, set the thread controller spring stop higher, then securely tighten the set screw (P).

It may be found advisable to increase the tension of the spring for coarse thread, or to lessen it for fine thread.

To increase the tension of the thread controller spring on the thread, loosen the tension stud set screw (Q, Fig. 17) and turn the tension stud (O, Fig. 17) over to the left with a screwdriver. To decrease the tension, turn the tension stud (O) over to the right, then securely tighten the stud set screw (Q).

Setting of Presser Bar

The presser Bar should be set so that when it is down and the feed dog is up, the roller presser clears it by about the thickness of a sheet of paper, for ease in turning corners. The presser bar may be raised or lowered by loosening the collar clamp screw (G, Fig. 4) and moving the collar up or down on the presser bar.

To Raise or Lower the Feed Dog

Usually when the feed dog is at its highest position, it should show a full tooth above the throat plate.

Remove the throat plate; clean the lint and dust from between the feed points and replace the throat plate; tip the machine back and turn the balance wheel until the feed dog is at its highest position; loosen screw (R, Fig. 18) in the feed lifting cam fork and raise or lower the feed dog as required, then tighten the screw (R).

When setting the feed dog on Machine 152W1, be careful that it does not drop low enough to strike the projection on the throat plate at the needle hole.

To Set the Needle Bar at the Correct Height

See that the needle is pushed up into its holder as far as it will go.

The needle bar which is in the machine when shipped from the factory has upon it (about two inches from the bottom) two lines .080 inch apart. When the needle bar is at its lowest point, the upper timing mark on the needle bar should be in line with the lower end of the needle bar bushing.

In case the needle bar is not set at the correct height, it can be adjusted by loosening the screw (F, Fig. 4) in the needle bar connecting stud and moving the needle bar up or down as may be required.

TO SET A NEW NEEDLE BAR WHICH HAS NO MARK. When the needle bar has risen .080 inch from its lowest position, the point of the hook should be opposite the center of the needle, and the eye should be about 1/16 inch below the hook point.

To Time the Sewing Hook

Remove the throat plate and turn the balance wheel over toward you until the lower mark across the needle bar is just visible at the end of the needle bar frame on the upward stroke of the needle bar. If the needle bar and sewing hook are correctly timed, the point of the hook will be at the center of the needle and about 1/16 inch above the eye.

In case the sewing hook is not correctly timed, turn the balance wheel over toward you until the needle bar has descended to its lowest point and has risen until the lower timing mark across the needle bar is just visible at the end of the needle bar frame.

Loosen the two screws in the hook shaft gear (S, Fig. 18) and turn the sewing hook until the point of the hook is at the center of the needle, after which securely tighten the two screws in the gear, leaving just enough play in the shaft for lubricating purposes.

To Set the Sewing Hook to or from the Needle

To prevent the point of the hook from dividing the strands of the thread, it should run as close to the needle (within the scarf) as possible.

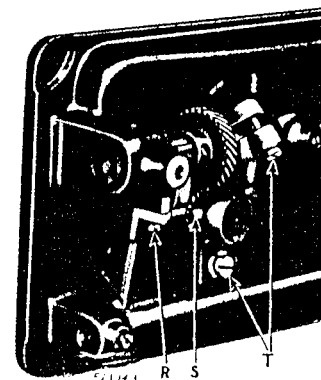

Fig. 18. Adjustment of Hook Saddle

Turn the balance wheel over toward you until the point of the sewing hook is at the center of the needle. Loosen the two screws (T, Fig. 18) underneath the bed of the machine and move the hook saddle to the right or left, as may be required, until the point of the hook is as close to the needle as possible without striking it, then securely tighten the two screws (T).

The function of the hook washer (needle guard) (Y, Fig. 20), which is attached to the bottom of the sewing hook, is to prevent the point of the hook from striking the needle if, when passing through the material, the needle is deflected toward the hook.

The needle guard can be bent with a small pair of pliers until it prevents the hook point from striking the needle, but it should not be bent outward enough to deflect the needle from its normal path.

To Remove the Bobbin Case Base from the Sewing Hook

Remove the two hook gib screws (W, Fig. 19) from the sewing hook, lift off the hook gib (X, Fig. 20) and remove the bobbin case base (U, Fig. 19).

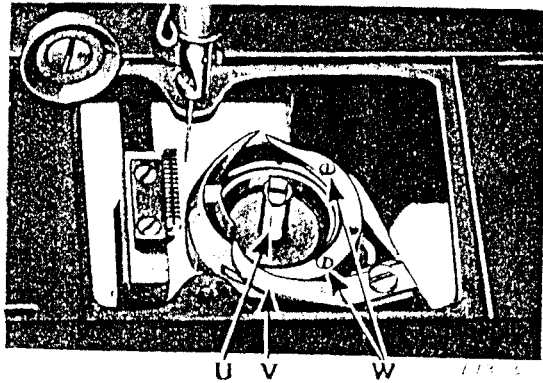

Fig. 19.

To Remove the Sewing Hook from the Machine

Remove the throat plate, feed dog and the bobbin case opening lever (V, Fig. 19). Also remove the bobbin case base, then take out the two screws from the hook shaft gear (S, Fig. 18) and lift out the sewing hook.

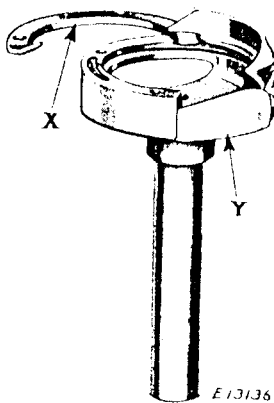

Fig. 20. Sewing Hook Removed from Machine,
Showing Hook Washer

Adjustment of Feed Regulating Spindle Head

The figures on the feed regulating spindle head (DD, Fig. 21), showing through the notch in the balance wheel, indicate the num-

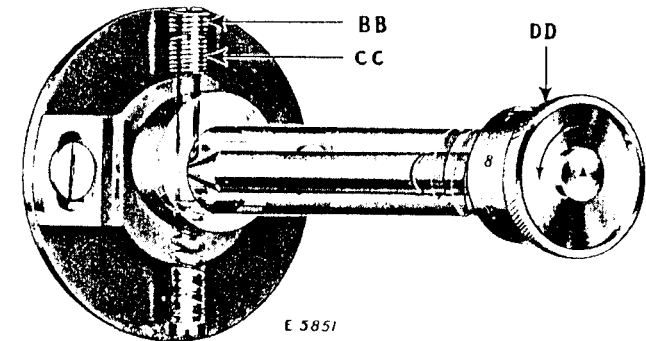

Fig. 21. "X-Ray" View of Feed Driving Eccentric
Regulating Bracket and Shaft, Showing
the Feed Regulating Spindle and Adjusting Screw (CC)
Which Comes in Contact with the Cone of the
Spindle to Gauge the Length of Stitch

ber of stitches to the inch which should be made. If more or less stitches are made, adjust as follows: Remove the screw (BB, Fig. 21), set the indicator at 20 and the feed dog at its highest point, a full tooth showing above the throat plate, then adjust screw (CC, Fig. 21) until 20 stitches to the inch is the result and replace check screw (BB) firmly.

By making this adjustment with the stitch indicator set at 20 stitches, the full range of the stitch regulator is automatically taken care of so that the number appearing in the notch in the balance wheel will always indicate the correct number of stitches to the inch that the machine is ready to make.

TO SET THE FEED REGULATOR SO THAT A STITCH LONGER THAN THE ONE DESIRED CANNOT BE MADE. Turn the spindle head (DD, Fig. 21) as far as possible in the direction indicated by the arrow in Fig. 21; remove check screw (BB) and adjust screw (CC) until the machine makes the desired number of stitches to the inch, then turn screw (BB) down tightly on screw (CC) as a check. The stitches may then be changed by turning the stitch regulator (DD) for shorter stitches, but operators cannot make a longer stitch than that limited by the above adjustment.

To Remove the Arm Shaft Connection Belt from Within the Arm

Slide the connection belt off lower pulley (B, Fig. 22); remove the feed regulating spindle head and balance wheel; loosen the arm shaft bushing (back) screw (C, Fig. 3) at the back of the arm and remove the bushing; lift the belt up through the arm cap hole as far as possible and draw it out through the space normally occupied by the bushing.

Owing to the fact that the sewing hooks make two revolutions to one revolution of the hook driving shaft, and that the feed lifting eccentric is on the hook driving shaft, it is possible to have the sewing hooks correctly timed without having the feed eccentric correctly timed. To overcome this, the plate (F, Fig. 5) is attached to the underside of the bed of the machine. This plate is marked with an arrow at its lower end and directly alongside of the plate is the collar (J, Fig. 5) mounted on the hook shaft, which is also marked with an arrow. When replacing the belt, replace the arm shaft bushing and securely fasten it in position by the screw (C, Fig. 3) at the back of the machine; replace the feed regulating spindle head and the balance wheel, and place the belt on the upper pulley, and then turn the balance wheel over toward you until the thread take-up lever is at its highest point. Then turn the hook shaft with the fingers until the two arrows, one on plate and the other on collar, are directly in line. Now, without disturbing either the arm shaft or the hook shaft, slip the belt over the lower pulley (B, Fig. 22). The feed will then be correctly timed with the needle bar.

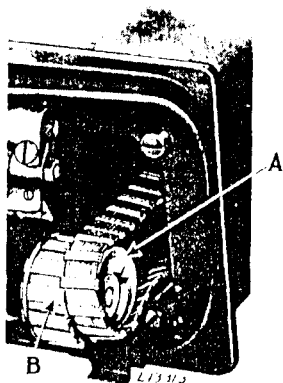

Fig. 22. Putting Belt on Lower Pulley with
Belt Replacer 235780

To facilitate the replacing of the belt on the lower pulley, use belt replacer No. 235780 (A, Fig. 22). Rest the replacer in the loop of the belt as shown in Fig. 22, having the notches in the replacer engage the two set screws in the hub of the pulley. Turn the balance wheel toward you until the belt is fully over the pulley, then remove the replacer.

NOTE: As belt replacer No. 235780 will serve for several machines, it is not regularly furnished with the machine, and must be ordered separately.