

SINGER
212U141

**Operator's
Guide**

SINGER*

212 **U141**

* A Trademark of THE SINGER COMPANY

Copyright©1981 THE SINGER COMPANY

All Rights Reserved Throughout the World

LUBRICATION

Use Singer oil "Type A" or "Type C"

Before starting machine
fill to high mark

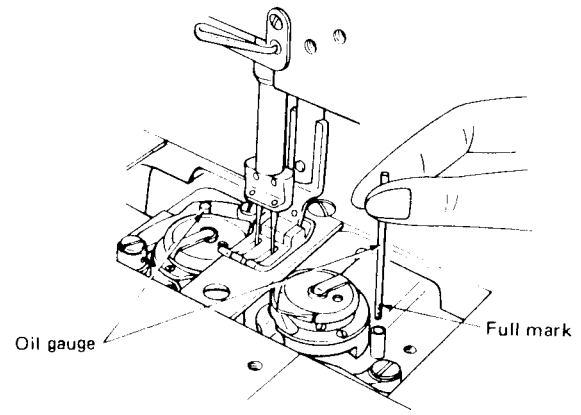
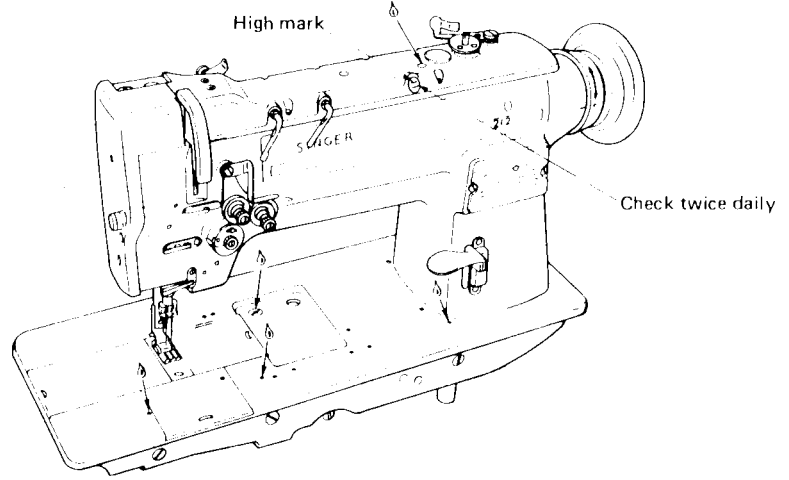

Remove the oil gauge and fill the oil reservoir to the full mark on the gauge

Apply oil at least twice daily to the oil gauge hole.

When the machine is in continuous use, the oil level of the reservoir must be checked twice daily.

LUBRICATION (Cont'd)

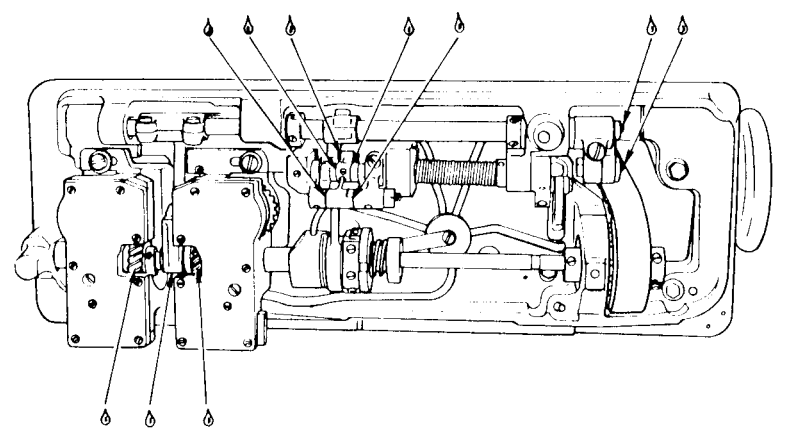

SPEED

Maximum Speed for this machine is 4,000 RPM.

It is recommended to run the machine 500 RPM slower than maximum speed for the first 100 hours.

NEEDLES

Use Singer needles.

Needles for Machine 212U141 are catalog 1901.

In sizes determined by size of thread and type of material being sewn.

SETTING THE NEEDLES

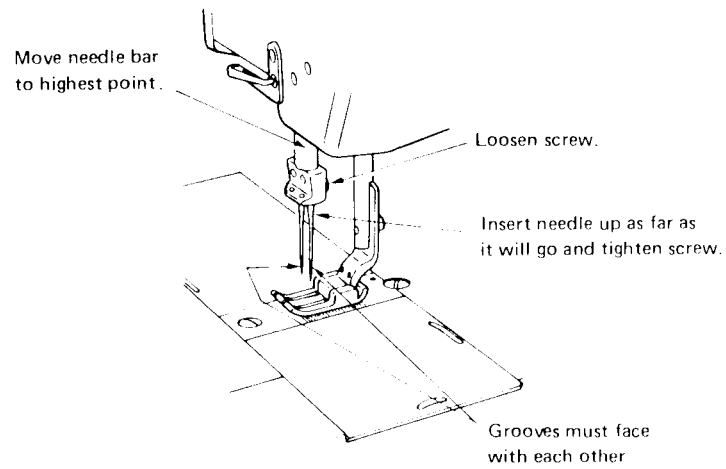

BOBBIN REMOVAL AND REPLACEMENT

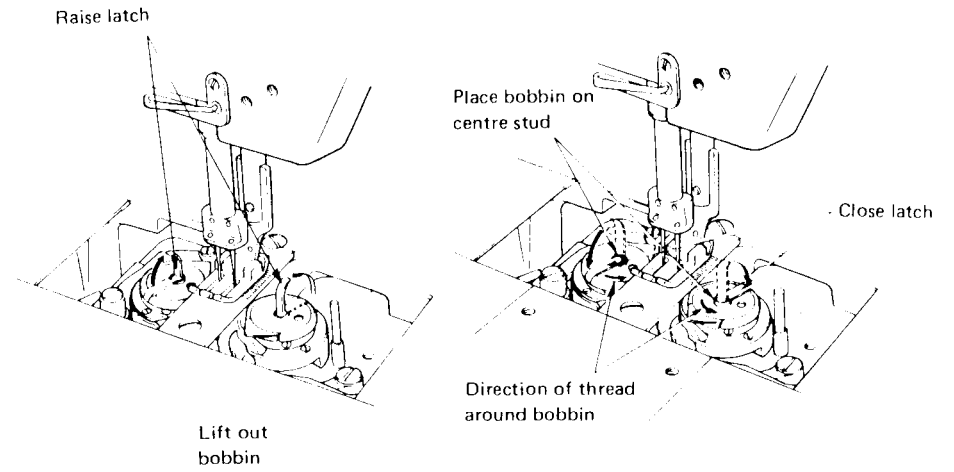

THREADING NEEDLES

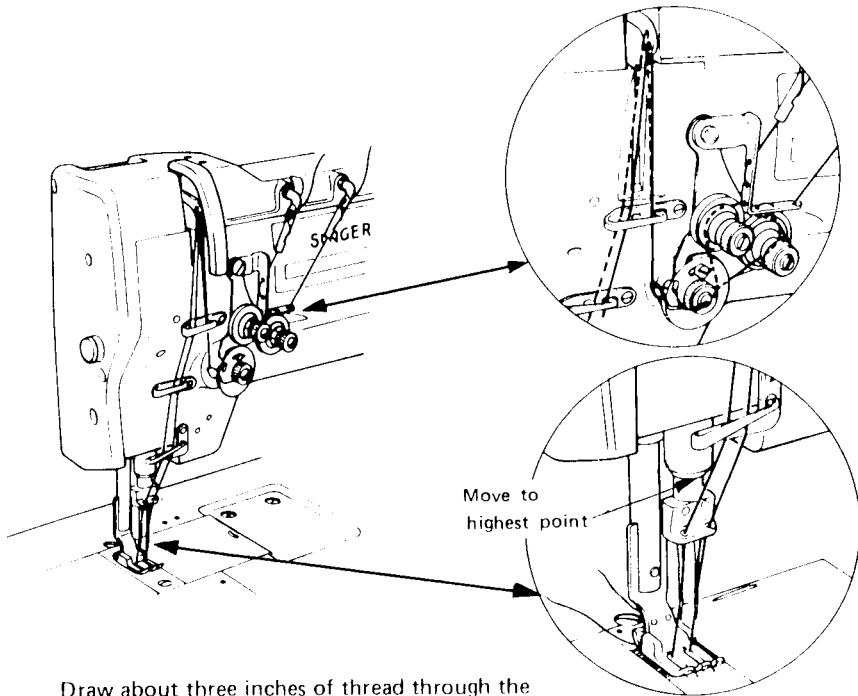

Draw about three inches of thread through the eye of each needle with which to begin sewing.

WINDING THE BOBBIN

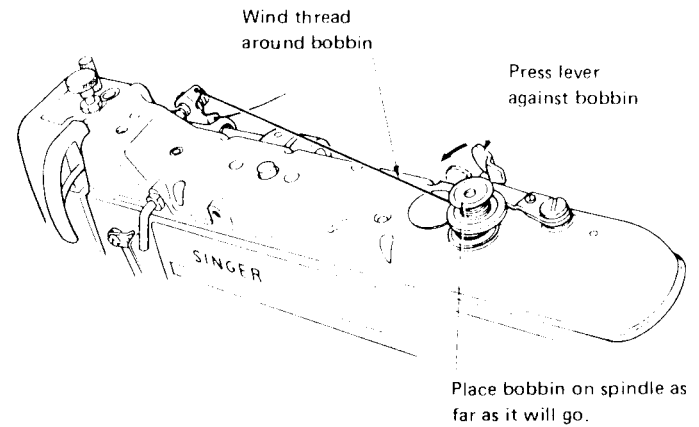

THREADING BOBBIN CASE

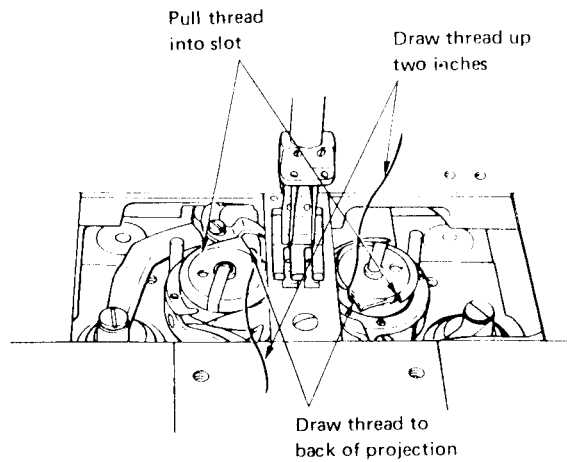

THREAD TENSIONS

Turn machine pulley until tension screw is accessible.

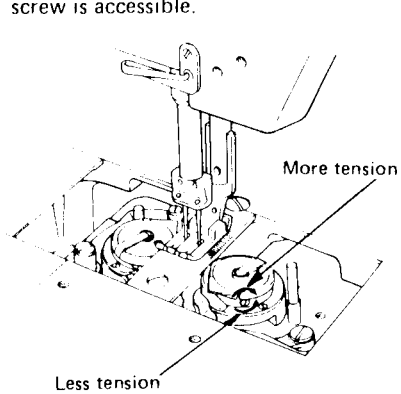

Tension on thread should be as light as possible while still sufficient to set stitch in material.

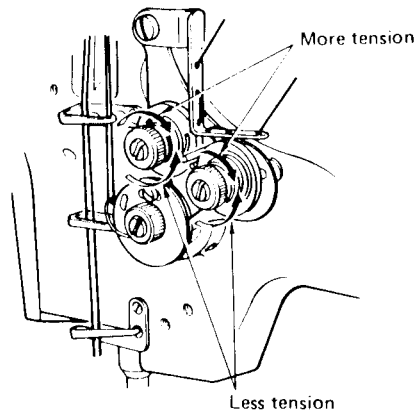

Regulate needle thread tension only when presser foot is down.

STITCH LENGTH REGULATION

1. STOP MACHINE.
2. Depress button.
3. Turn pulley to you slowly until button drops into notch.
4. Turn machine pulley in direction (+) when a longer stitch is desired (less spi) and in direction (-) when a shorter stitch is desired (more spi).
5. Release button.

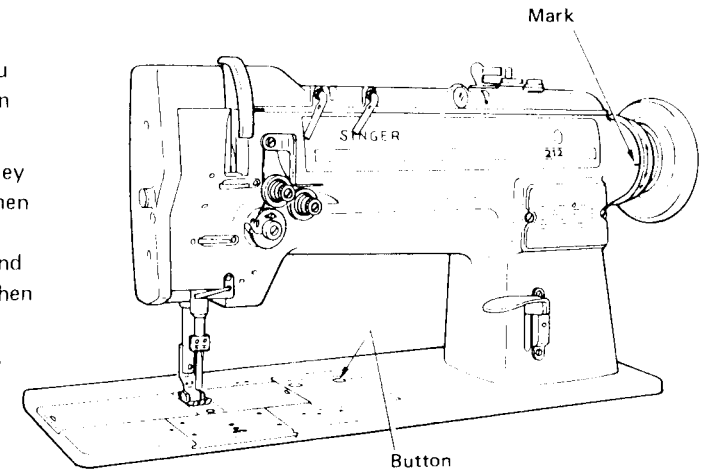

CAUTION:

Never depress the button while the machine is running. Make certain that the button is disengaged before starting machine.

CHANGING TO REVERSE FEED

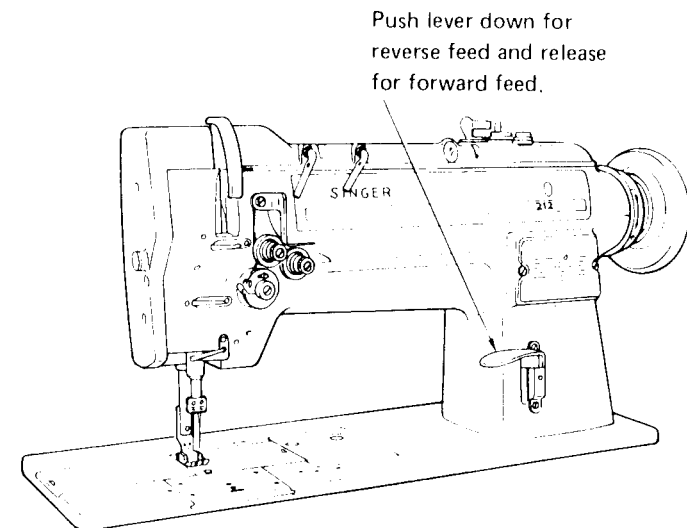

PRESSER FOOT PRESSURE

The pressure on the material should be as light as possible, while still sufficient to insure correct feeding.

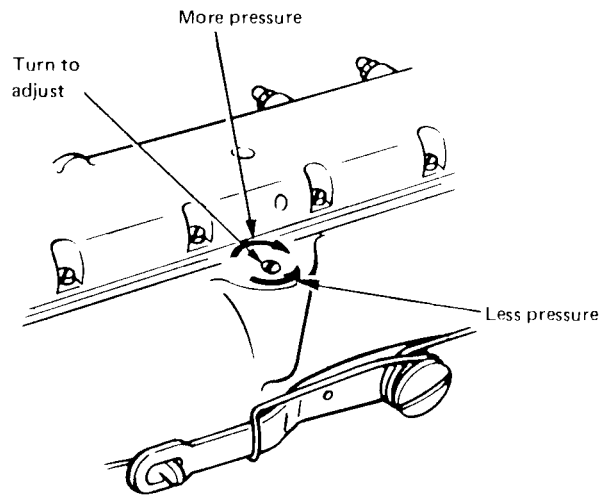

CLEANING

Clean out any lint or other waste around the hook, between the feed rows on the underside of the throat plate and in the hook area of the oil pan.

Form U3239 (781)
Part No. 543244 002
Printed in Japan