

**SINGER**  
**312T**

# OPERATOR'S GUIDE

## Principal parts of Model 312T Machine

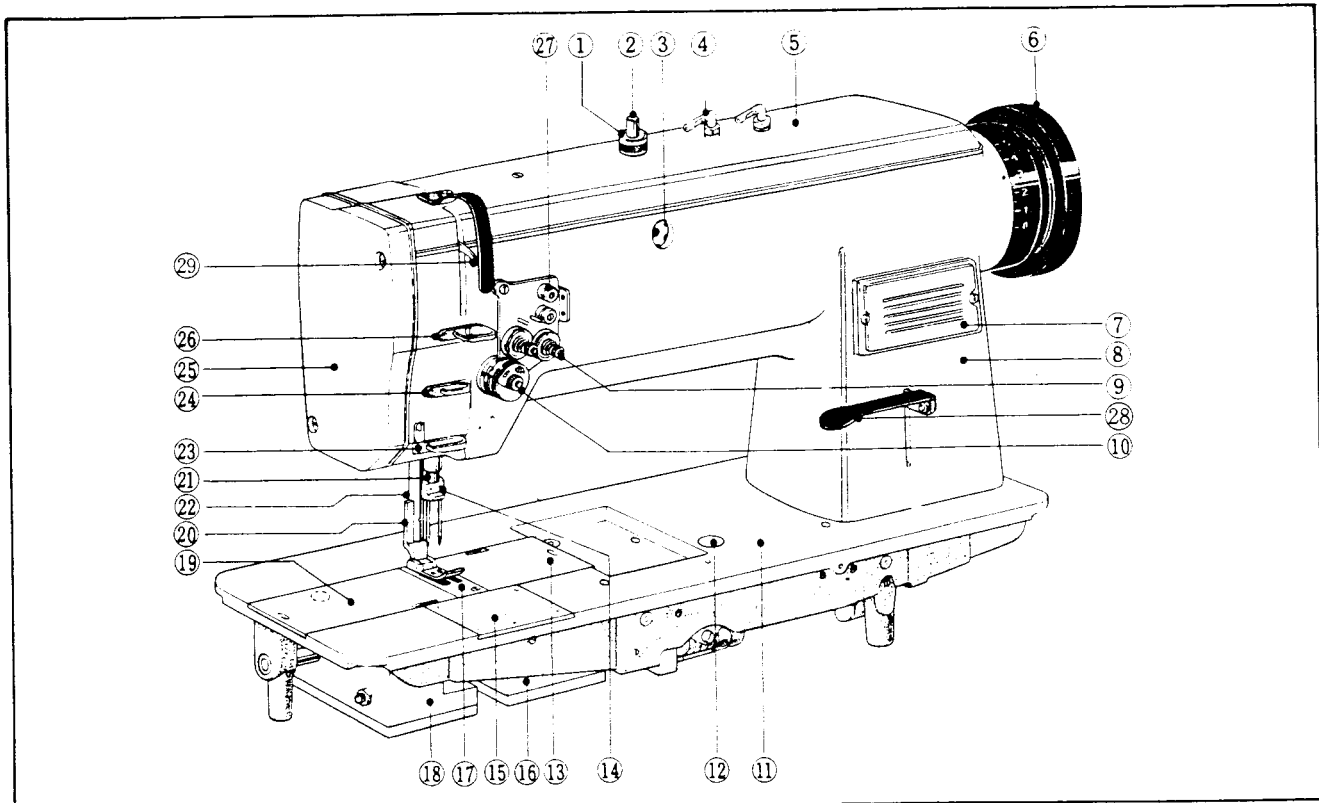

- |                                    |                                   |                            |
|------------------------------------|-----------------------------------|----------------------------|
| 1) Press stud for oil plunger.     | 11) Bed.                          | 21) Needle bar.            |
| 2) Press bar for oil plunger.      | 12) Stitch regulator push button. | 22) Presser bar.           |
| 3) Oil level indicator.            | 13) Slide plate (right).          | 23) Thread guide (lower).  |
| 4) Thread guide (top of arm).      | 14) Needle clamp                  | 24) Thread guide (middle). |
| 5) Arm top cover.                  | 15) Slide plate (front).          | 25) Face plate.            |
| 6) Machine pulley.                 | 16) Hook saddle. (right)          | 26) Thread guide (upper).  |
| 7) Front cover.                    | 17) Throat plate.                 | 27) Pre-tension.           |
| 8) Arm                             | 18) Hook saddle. (left)           | 28) Feed reverse lever     |
| 9) Upper thread tension regulator. | 19) Slide plate. (left)           | 29) Thread take-up lever   |
| 10) Thread controller.             | 20) Presser foot.                 |                            |

### How to install and adjust the knee lifter

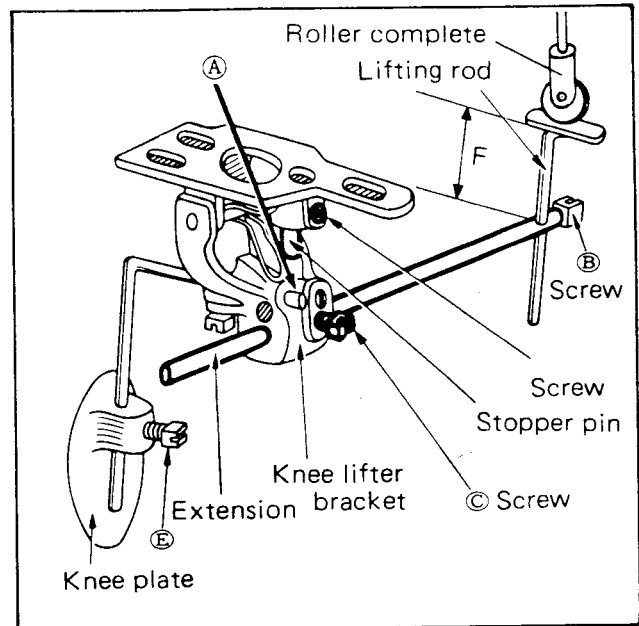
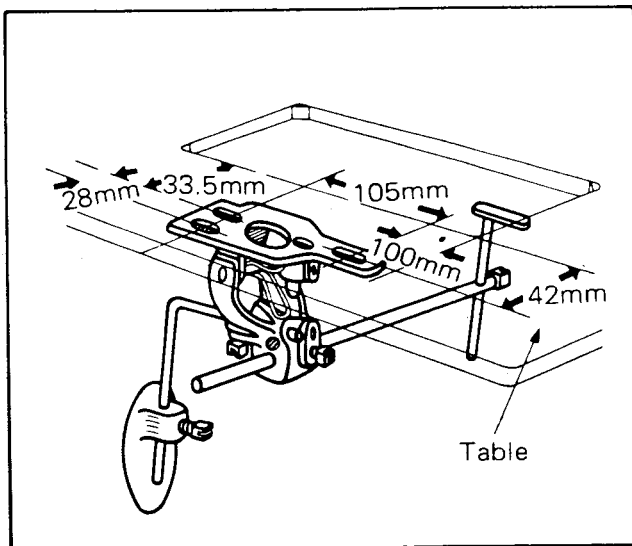

# How to use the machine

## 1. To set the needles

Caution: Before making the following adjustment, be sure to turn off the power source switch.

Insert the needles into the needle clamp as far as they will go, with the long grooves facing each other. Then tighten the needle clamp screws.

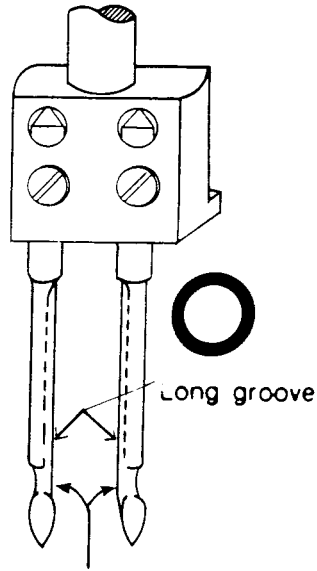

Insufficient insertion

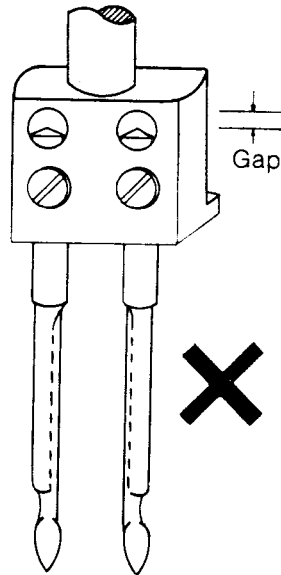

Needles facing the wrong direction.

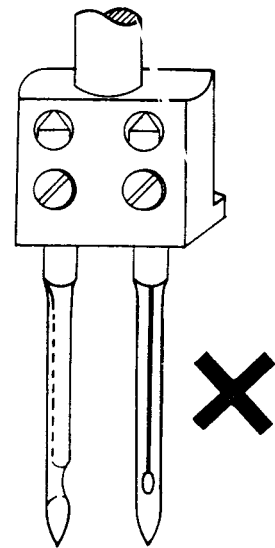

## 2. To wind the bobbin

- When winding a bobbin with fine thread such as nylon or tetron threads, the bobbin should be wound loosely using a light tension.
- If bobbin does not wind evenly, move tension bracket to the left or right as required. If bobbin winds high on right, move bracket to left, and if bobbin winds high on left, move bracket to right.
- Bobbin should be wound to  $4/5$  of its capacity. For more thread on the bobbin, turn adjusting screw clockwise; for less thread, turn screw counterclockwise.

Note: Be sure to raise the presser foot when running the machine without material under the foot.

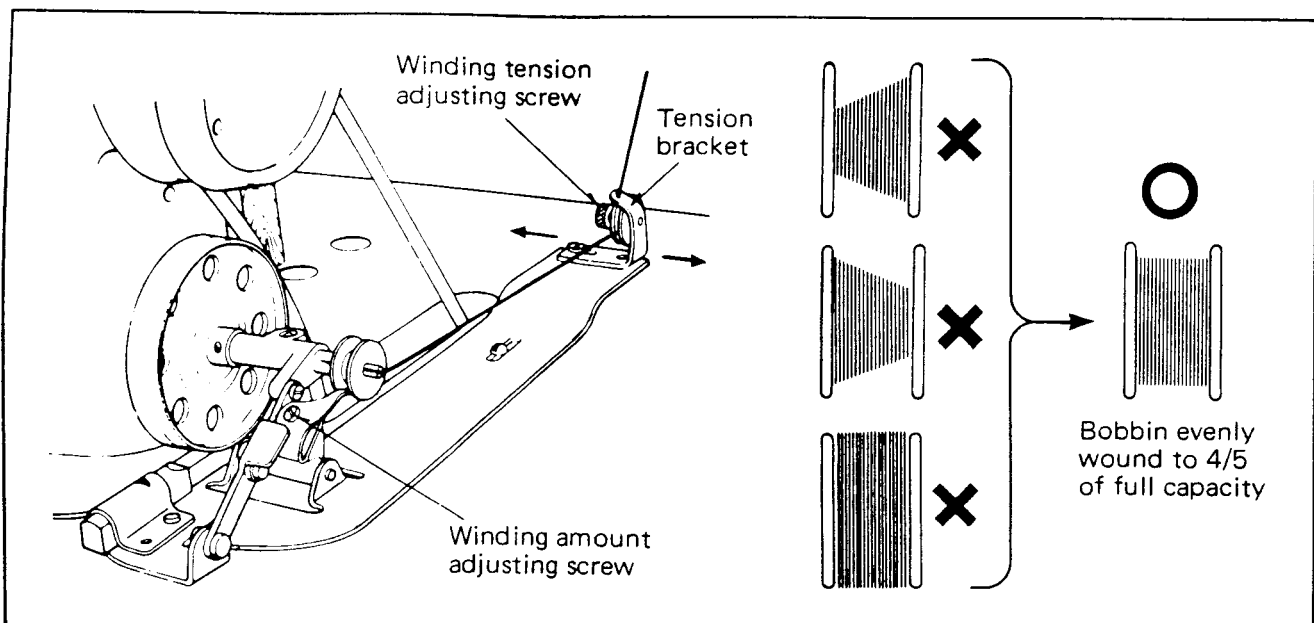

# How to use the machine

## 3. Threading the machine

Note: The thread guide (A) should be positioned just above the thread spool.

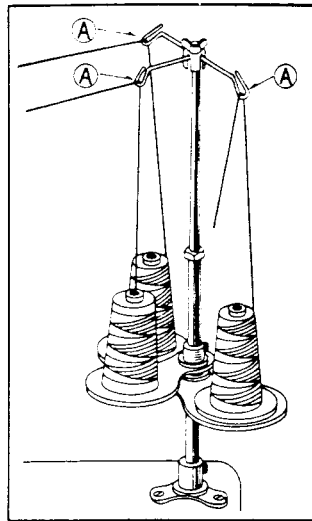

Raise the thread take-up lever to its highest position and pass the needle thread from the thread stand through threading points in the order shown below.

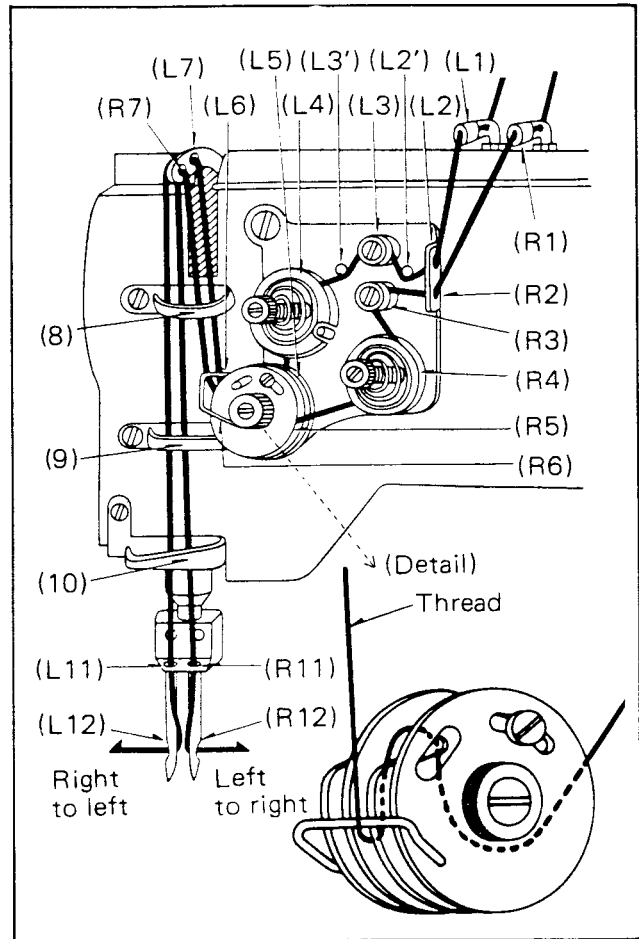

## 4. To adjust stitch length

Stitch length adjustment is achieved simply by depressing a button in the machine bed and turning the machine pulley.

1. Depress button and turn machine pulley slowly toward you until button sinks further into the machine bed and the machine pulley stops.
2. Depress the button harder and turn machine pulley toward you, or away from you, to set stitch length graduation on the marking on arm. Release the button when desired setting is obtained.

Caution: NEVER depress the button while the machine is running.

To change the direction of feed for back tacking, depress feed reverse lever to lowest position until back tack is completed.

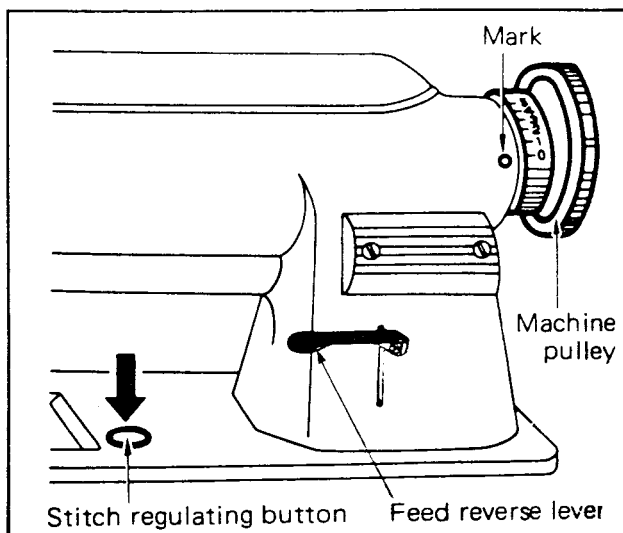

## 5. To replace the bobbin

Hold bobbin so that thread will unwind in the direction shown in illustration below and place it in the bobbin case.

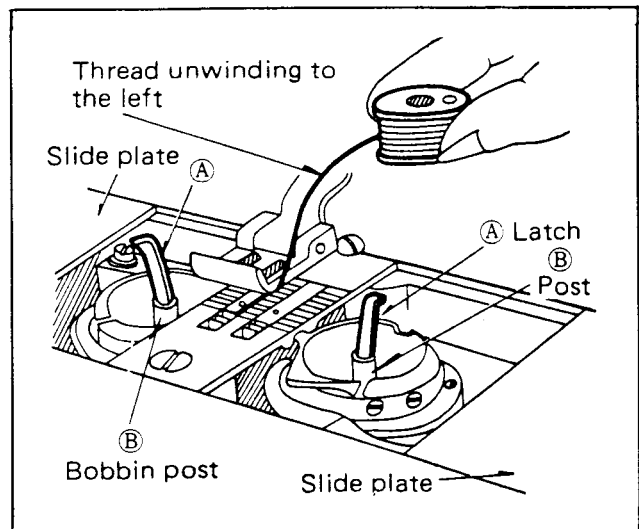

# How to use the machine

## 6. Threading the bobbin case

1) Pull thread into slot ① in bobbin case and draw it through between horn ② and bobbin case opener.

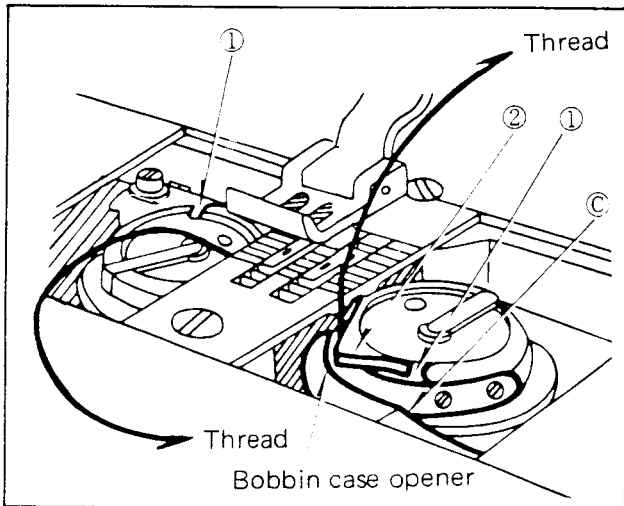

2) Hold needle threads with left hand and turn machine pulley until needles bring up bobbin threads. Pull ends of bobbin threads up through throat plate and place both needle and bobbin threads diagonally under presser foot.

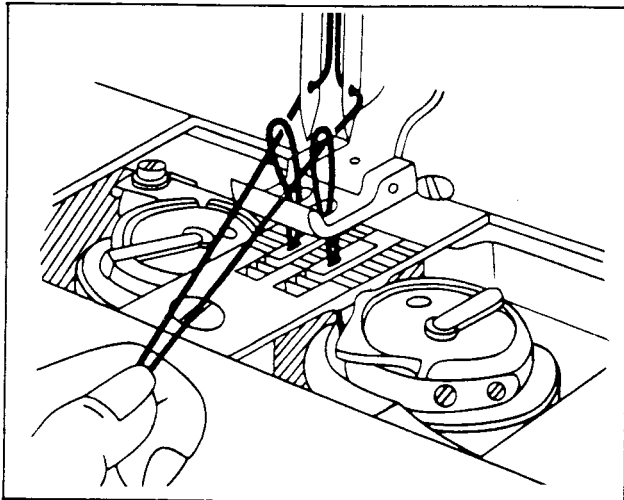

## 9. Bobbin thread tension

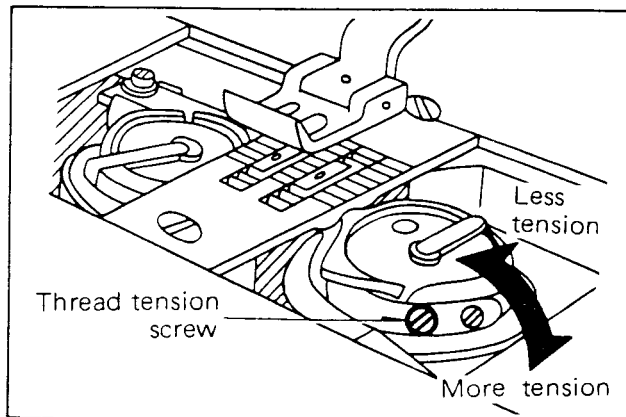

## 7. Adjustment of thread tension

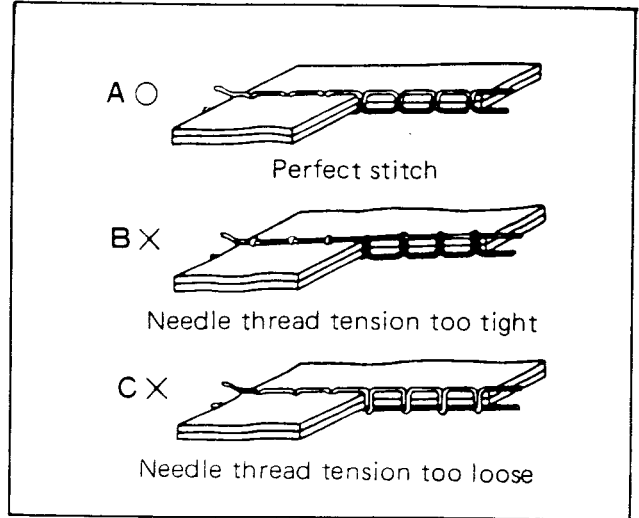

## 8. Needle thread tension

- Needle thread is adjusted according to the bobbin thread tension.
- Needle thread tension is adjusted by tension regulating thumb nut.

For special fabric sewing with special thread, the desired tension can be obtained by adjusting the tension and range of movement of the take-up spring.

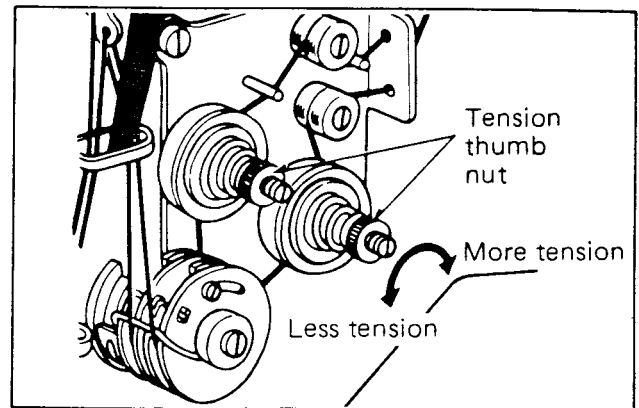

## 10. Adjustment of presser foot pressure

Pressure on the presser foot is to be adjusted in accordance with materials to be sewn.

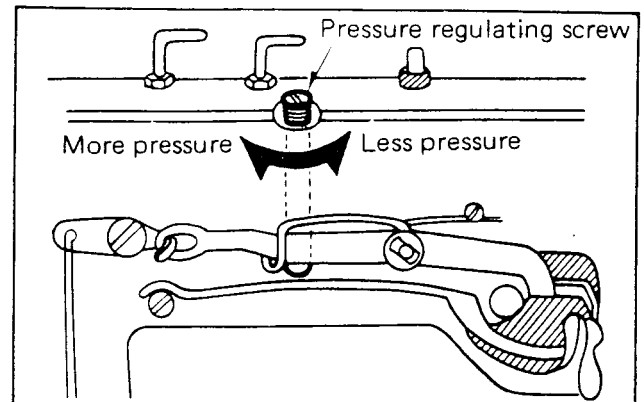

## Trouble & Repair

Trouble	Causes	Corrective Action
<b>Skip Stitching</b>	1) <b>Needle</b> o Bent needle o Not suited for thread being used	Change the needle with a new one. Replace with needle suited for thread being used.
	2) <b>Improperly set needle</b> o Insufficient insertion o Incorrectly inserted needle	Insert properly as instructed in manual. Set needle holes parallel to front edge of bed. Set the needles with long grooves facing each other.
<b>Loose Stitches</b>	1) <b>Needle thread tension too loose</b>	Turn tension regulating thumb nut clockwise to increase tension.
	2) <b>Take-up spring tension too weak</b>	Turn tension stud clockwise to increase tension.
	3) <b>Bobbin thread tension too loose</b>	Turn bobbin case tension screw clockwise to increase tension.
<b>Thread Breakages</b>	1) <b>Poor quality thread</b>	Use better quality thread.
	2) <b>Needle</b> o Bent needle o Improperly set needle o Needle too small for thread being used	Change the needle with a new one. See item 2) of skip Stitching.  Replace with correct size needle for thread being used.
	3) <b>Needle thread tension too tight</b> o Lint accumulated between tension discs o Uneven or over wound bobbin o Lint accumulated in bobbin case o Broken or bent bobbin case tension spring o Improperly inserted bobbin	Turn tension regulating thumb nut counterclockwise to decrease tension. Remove thumb nut and tension discs and clean with a lint brush.  Replace with bobbin evenly wound to 4/5 of its full capacity. Remove bobbin case and clean with a lint brush.  Replace with a new one.  Insert bobbin correctly so that it will rotate in counterclockwise direction when the thread is pulled out.
<b>Puckering</b>	1) <b>Size of needle and thread incorrect for fabric being sewn</b>	Use correct size needle and thread for the fabric being sewn.
	2) <b>Needle and bobbin thread tensions too tight</b>	Adjust needle thread tension by adjusting tension thumb nut and take-up spring. Adjust bobbin thread tension by turning tension screw.
	3) <b>Excessive presser foot pressure</b>	Decrease pressure on presser foot by turning pressure regulating screw counterclockwise.

# Before Starting the machine . . . . .

## 1 Lubrication-1

Before starting the machine, the oil reservoirs shown in illustration below must be filled with oil. Run machine at a moderate speed for 10 to 15 minutes until the oil is circulated to all parts in movable contact.

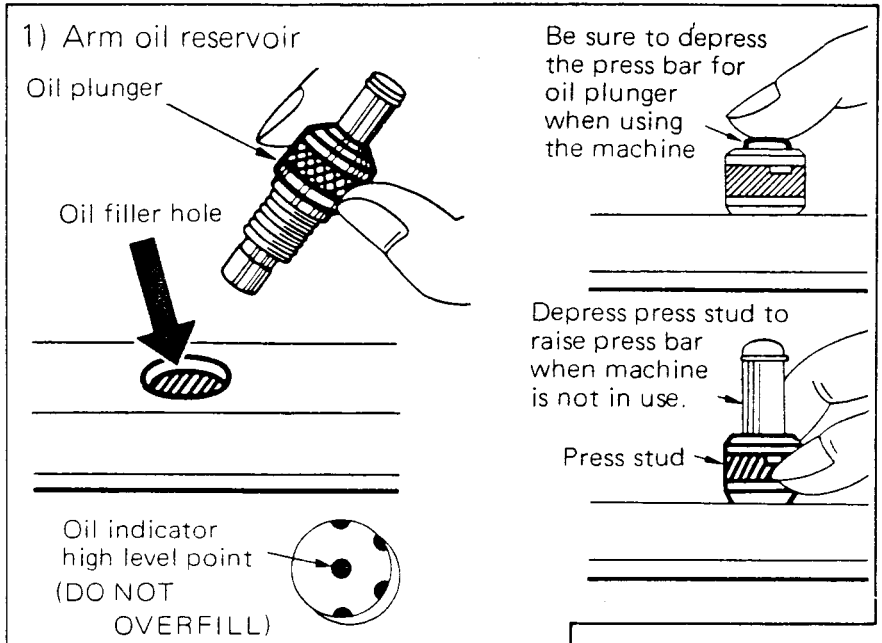

## Lubrication-2

Apply 5 - 6 drops of oil to areas indicated with

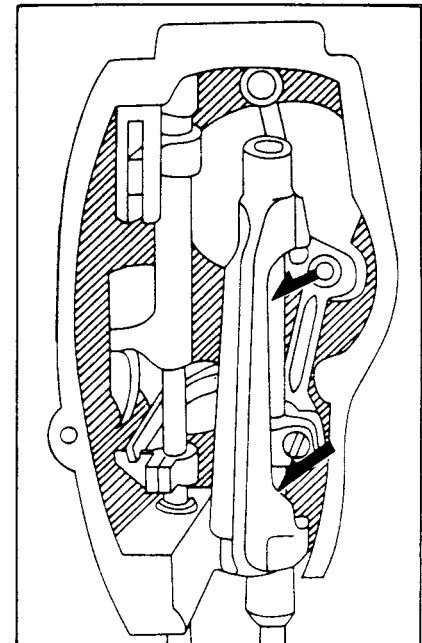

## 2) Bed oil reservoir

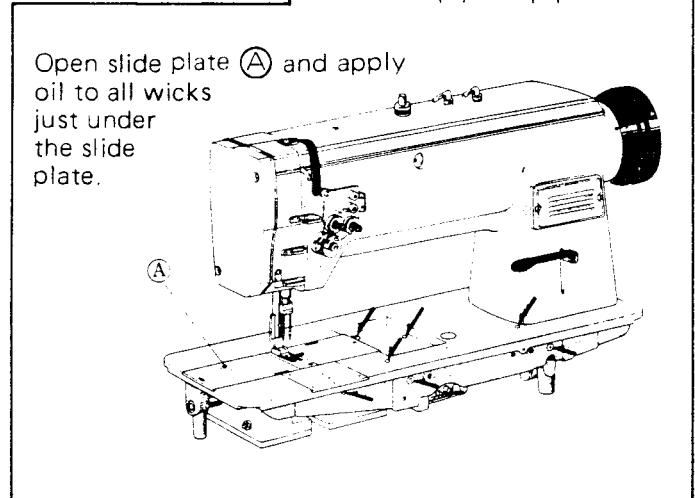
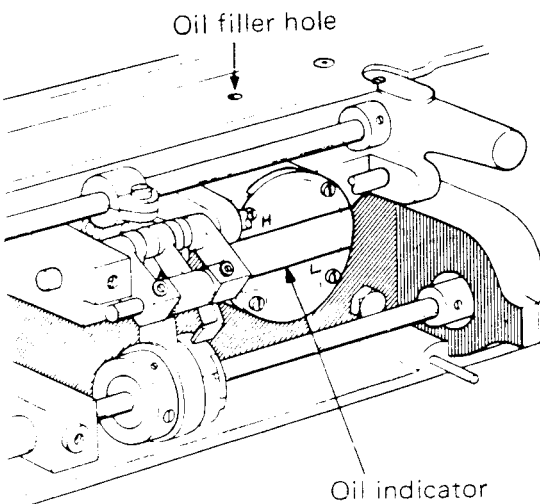

## 3) Hook saddle oil reservoir (left & right)

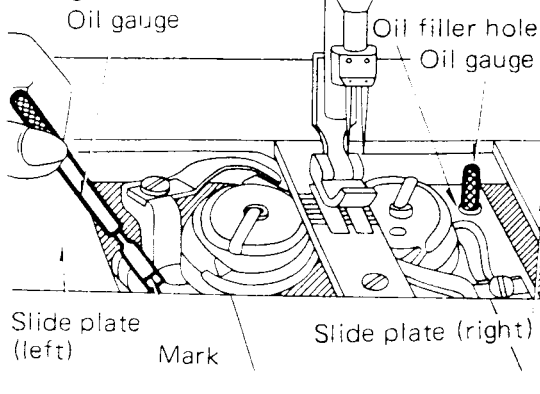

## 2. Adjustment of rotating hook oil flow regulator

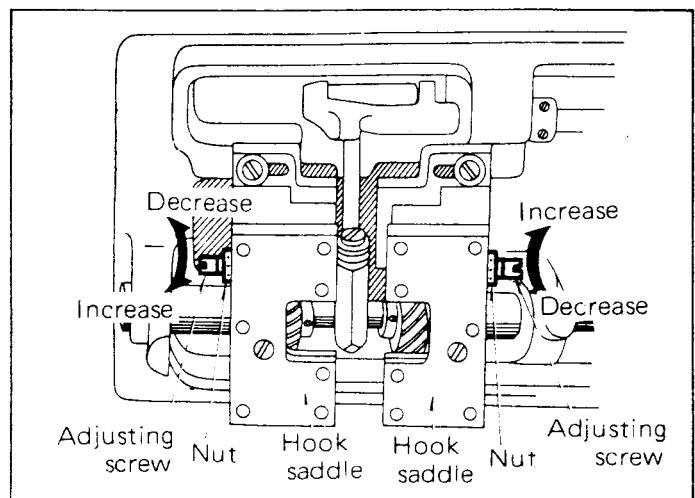

## Cleaning

Machine should be periodically cleaned with small brush to remove all lint and other waste which accumulates around the hooks, throat plate, feed dog, thread tension regulator and thread controller disc:

### Installation of rubber cushions

Four rubber cushions are used to prevent excessive vibration and noise of the machine. These are fitted in the four corners of the table cut-out.

o Cut 20mm (13/16") radius and 13mm (1/2") deep seats for the rubber cushions as shown in the diagram, paying particular attention to the depth of corners.

o Fasten the rubber cushions to the four corners of the table cut-out with nails as shown in the diagram.

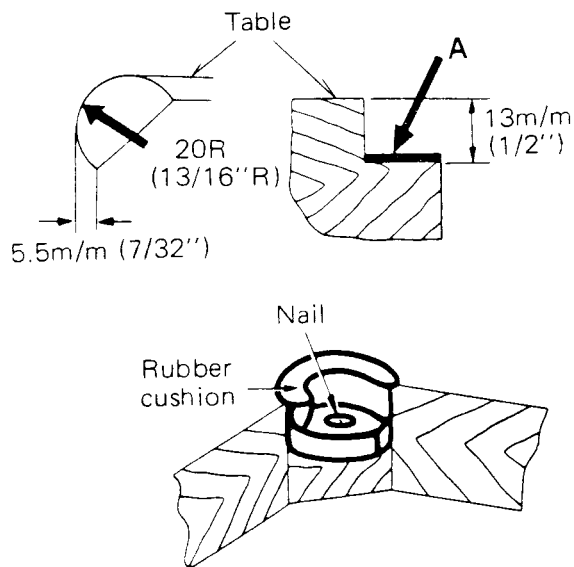

## Specifications

Number of needles	Two
Speed	3,500 s.p.m.
Rotary hook	Regular size
Max. stitch length	5mm (5 s.p.i.)
Needle bar stroke	33.4mm (1-5/16'')
Presser foot lift	7.2mm (9/32'')
Space at right of needle	245mm (9-11/16'')
Needles	CAT. No. 1901 #14
Feed reverse lever	Hand or foot operated
Gauges (Standard)	4.8mm (3/16'') and 6.4mm (1/4'')
Bed dimensions	517mmx178mm (20-3/8''x 7'')



# TABLE CUT-OUT

ALL DIMENSIONS IN MILLIMETERS (mm)

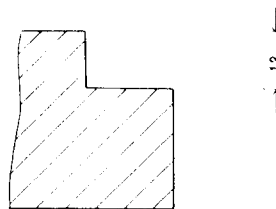
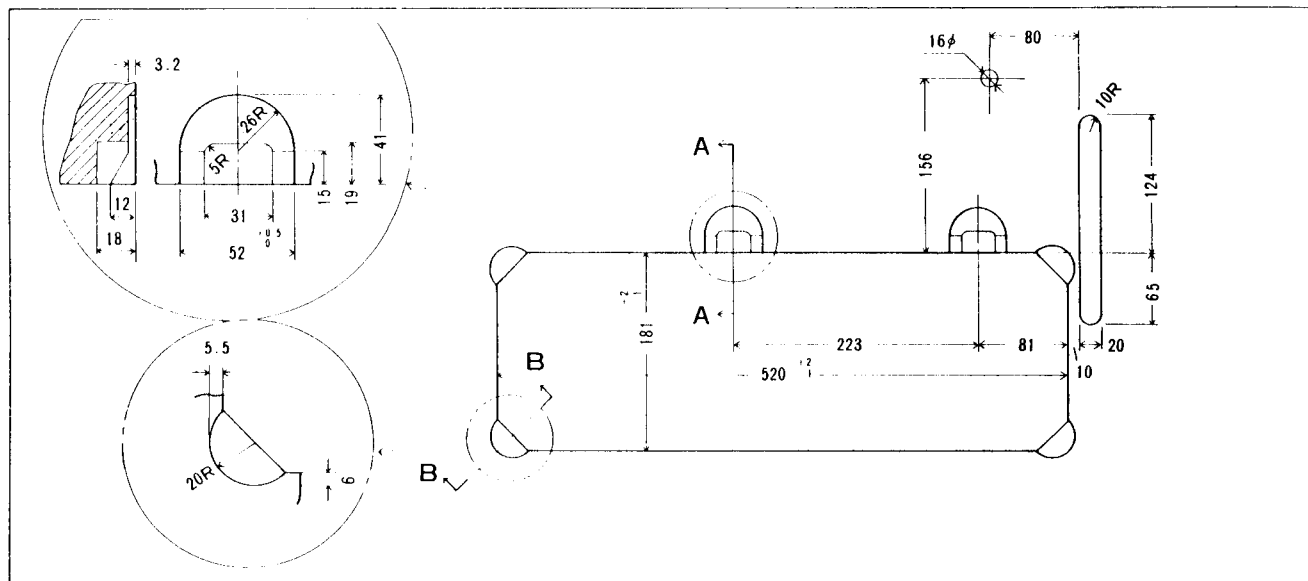
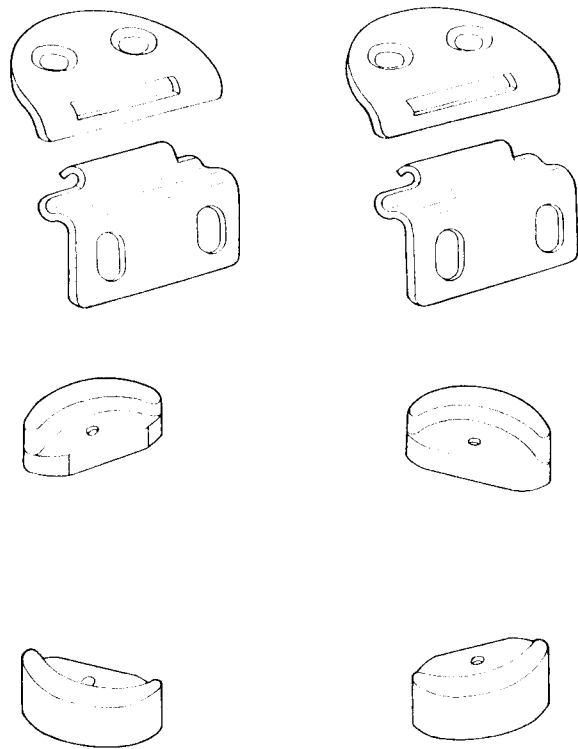

SECTION B

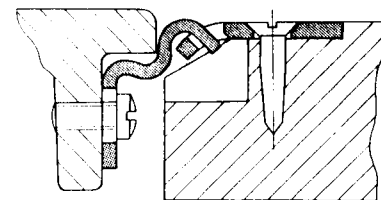

SECTION A