

INSTALLATION AND OPERATOR'S GUIDE

FOR

SINGER PATTERN FORMER 7902

JANUARY 13, 1989

SINGER NIKKO CO., LTD.

Introduction

The model 7902 was designed to give customer high workability, high performance and better efficiency with simple maintenance in pattern sewing.

For best sewing results, we suggest you to take a few moments to read through this guide book as you sit your new machine.

<u>Contents</u>	<u>Page</u>
1. Name of principal parts	2
2. Specification	3
3. Installation	3
4. Adjustments	
1) To adjust machine speed	4
2) To adjust air cylinders	4
3) To adjust mouse speed	5
4) To adjust feed dog height	5
5) To adjust sensitivity of photoelectric switch	5
6) To apply reflection tape	6
7) Function and application of proximity switch	6
8) To apply tagger	8
9) To replace the trimmer knife	8
10) To adjust the trimmer knife	9
5. Operation	
1) Operation box	9
2) Test operation	10
6. Check and maintenance	
1) Oiling	11
2) Tilting machine back	11
3) Replacing feed rubber	12
4) Filter and regulator	12
5) Lubricator	12
6) Limit switch on mouse cylinder	12

1. Name of principal parts (See Fig. 1 and Fig. 2)

- | | |
|---------------------------|--------------------------|
| ① Edge trimmer device | ⑩ Filter and regulator |
| ② Photoelectric switch | ⑪ Lubricator |
| ③ Proximity switch | ⑫ Air switch |
| ④ Mouse rail | ⑬ Stand |
| ⑤ Presser lifter cylinder | ⑭ Caster |
| ⑥ Operation box | ⑮ Pattern guide cylinder |
| ⑦ Power switch box | ⑯ Pattern push cylinder |
| ⑧ Sequence control box | ⑰ Trimmer knife |
| ⑨ Start/Stop switch | |

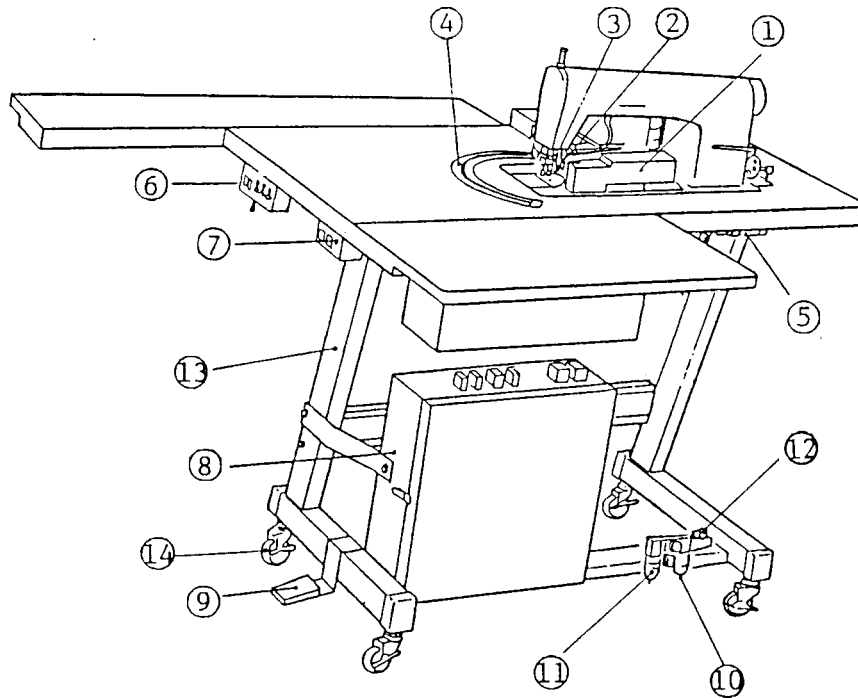

Fig. 1

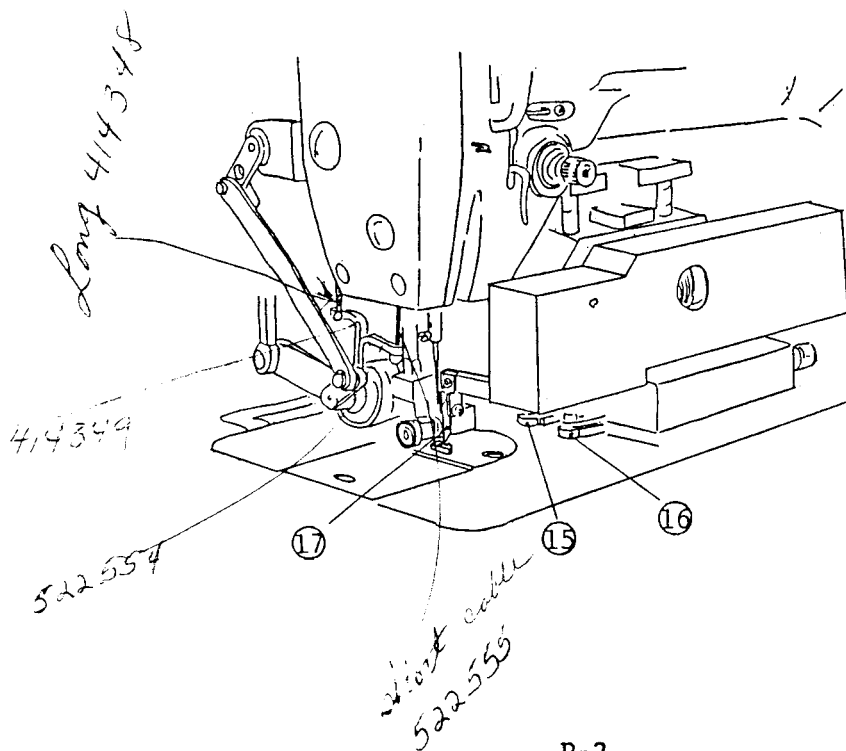

Fig. 2

2. Specification

- . Machine head: Single needle lockstitch machine with puller feed (model 591UX313S1)
- . Motor: Needle positioning motor (U39 series, 4 pole, 250 watt)
- . Sequence control: Sequence controller (HITACHI E-20HR)
- . Machine speed: 1600 s.p.m. max. (depends on pattern size)
- . Stitch length: 3 mm max.
- . Trim margin: 4 mm fixed
- . Presser foot height: 14 mm max.
- . Backtack: 0-9 stitch adjustable
- . Required air pressure: 5 kg/cm²
- . Air consumption: 25 L/min.
- . Overall dimensions: L 1,100 mm X W 1,000 mm X H 900 mm
- . Weight: 65 kg

3. Installation

- 1) Unpack
- 2) Assemble casters to the stand
- 3) Put presser lifter bell crank into the oil pan
- 4) Pour oil into the oil pan
- 5) Mount machine head on the table
- 6) Install the belt
- 7) Install the bobbin winder device
- 8) Connect air tubes to the cylinders mounted on machine head in accordance with indicated color
- 9) Connect lead wires to the receptacles on the sequence controller and motor control box
- 10) Assemble mouse plate and second mouse (see Fig. 5)
- 11) Connect air tube to the air regulator and set air pressure to 5 kg/cm²
- 12) Connect power line to electrical outlet

4. Adjustments

1) To adjust machine speed

Machine speed for normal sewing operation is 1600 s.p.m. and this speed is adjusted by means of the volume switch provided in the sequence control box.

2) To adjust pattern guide cylinder and pattern push cylinder.

When the pattern stops at the corner, pattern push cylinder serves its function of pushing the corner of pattern slot against the boss on the throat plate while the mouse turns the pattern as well as pushing the pattern at completion of sewing operation.

Pattern guide cylinder constantly pushes the pattern during sewing operation allowing the outer side of the pattern slot to travel along the boss on the throat plate.

Pressure of these two air cylinders should be approx. 2 kg/cm^2 . This adjustment is made by turning the two air regulators (see Fig. 3) so that the cylinder rod can be pushed in with your little finger.

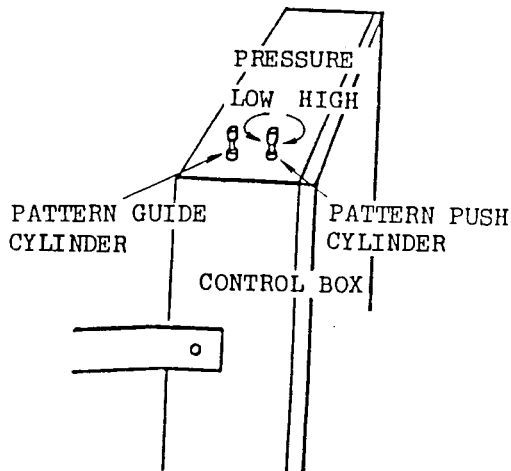
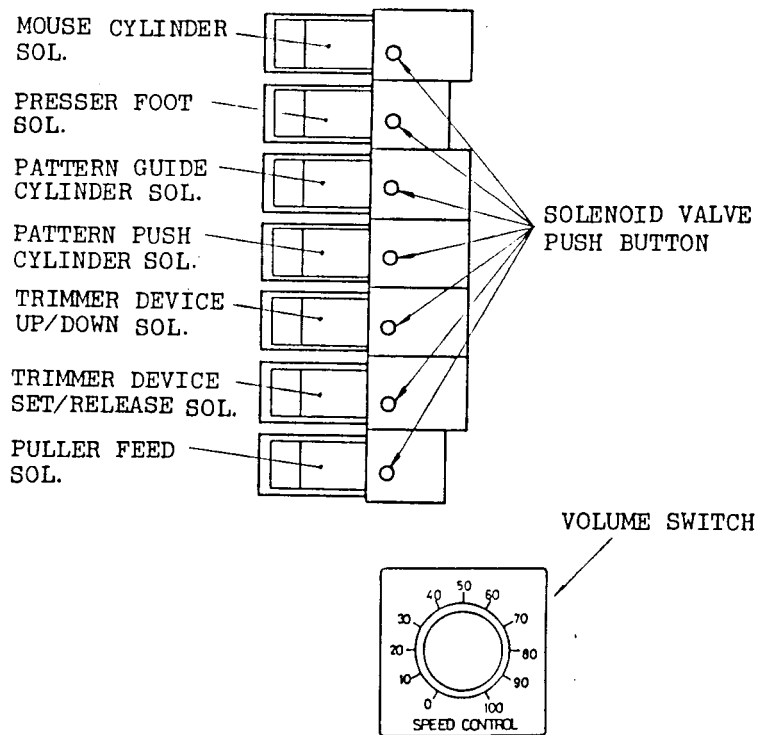

Fig. 3



INSIDE OF CONTROL BOX

Fig. 4

3) To adjust mouse speed

The push out speed of the mouse is adjusted by turning the speed control knob provided on the mouse cylinder (see Fig. 5). To make mouse speed slower, turn speed control knob clockwise and to make it faster, turn knob counterclockwise.

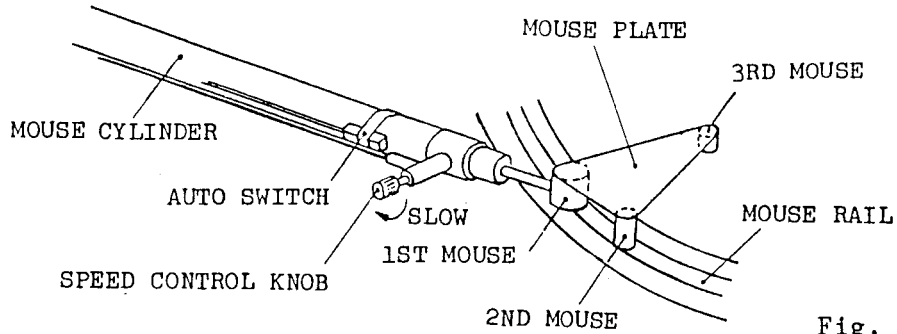

Fig. 5

4) To adjust feed dog height

The feed dog height should be set so that the top of its surface is approx. one half of the height of the throat plate boss.

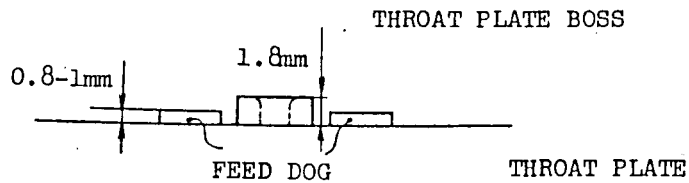

Fig. 6

5) To adjust sensitivity of photoelectric switch

The photoelectric switch is actuated by the reflection tapes applied to the pattern. The first pattern actuates the photoelectric switch to move the mouse forward and the second tape actuates the photoelectric switch to move the mouse back.

Sensitivity of photoelectric switch varies depending on the distance between photoelectric switch and reflection tape. The sensitivity becomes better at closer distance and worse when distance becomes far. Sensitivity also varies depending on the thickness of the pattern, therefore it should be adjusted by means of the sensitivity adjusting knob provided on the amplifier for photoelectric switch so that it detects only the reflection tape. (Pilot lamp should be green when the reflection tape reach to the underside of photoelectric switch.)

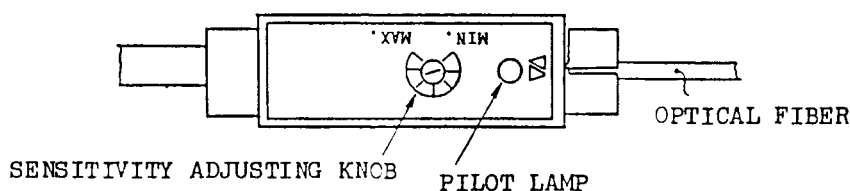

Fig. 7

6) To apply reflection tape

Reflection tape should be normally applied as shown in Fig. 8 and Fig. 9. There is a time lag before the mouse starts to move when the photoelectric switch detects reflection tape. Location to apply the reflection tape differs a little depending on machine speed and stitch length.

Especially, location of reflection tape for curved portion is very important as well as low speed setting adjusted by the digital switch provided on the operation box and mouse speed adjustment.

CORNER

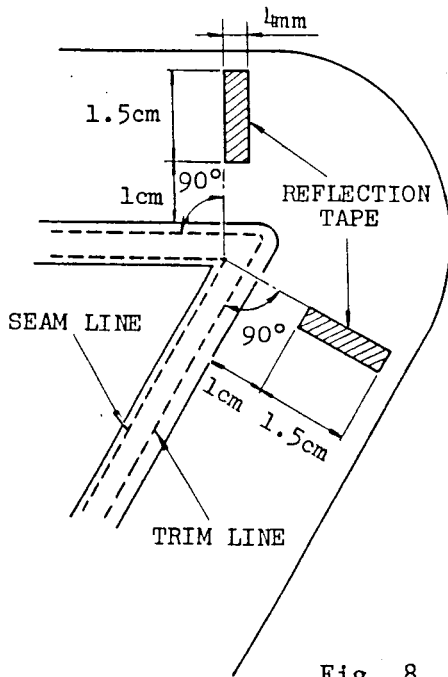

Fig. 8

CURVE

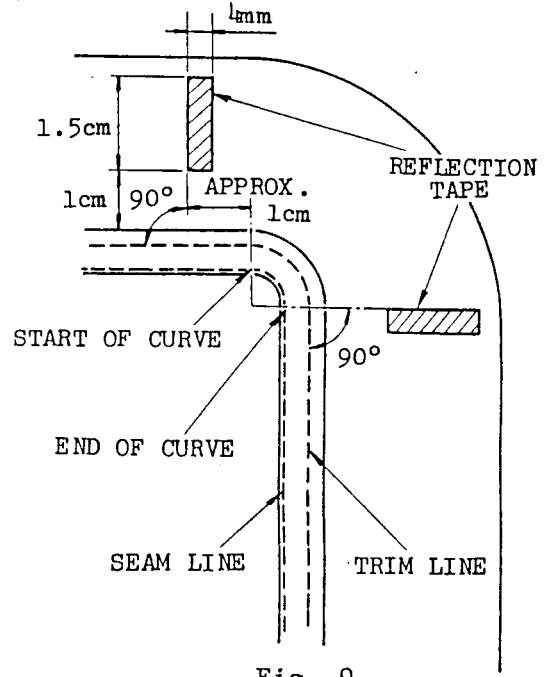

Fig. 9

7) Function and application of proximity switch

The proximity switch is a switch to detect metal taggers for detection of sewing end and inverting stop or non-stop setting as shown in Fig. 11 and Fig. 12. Proximity switch detects the end of sewing and when it stays on for over 0.3 seconds the signal for thread trimming is output by the sequence controller. When proximity switch turns off within 0.3 seconds, it will cause the snap switch (NON-STP) located on the operation box to function inversely to the preset operation. That is, when snap switch is set to "NON", the machine will stop at the corner and when set to "STP", the machine will continue to run instead of stopping. (see Fig. 10).

DETECTION OF END OF SEWING : PROXIMITY SWITCH

INVERTING STOP OR NON-STOP SETTING : PROXIMITY SWITCH

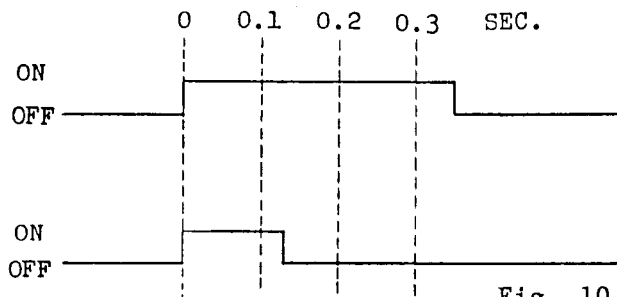

Fig. 10

For instance, work piece such as cuffs where both corner and curve exist, the curved portion are sewn while turning the pattern, whereas at corner, the needle is stopped in the down position to turn the pattern. (see Fig. 11 and Fig. 12)

When sewing at NON side.

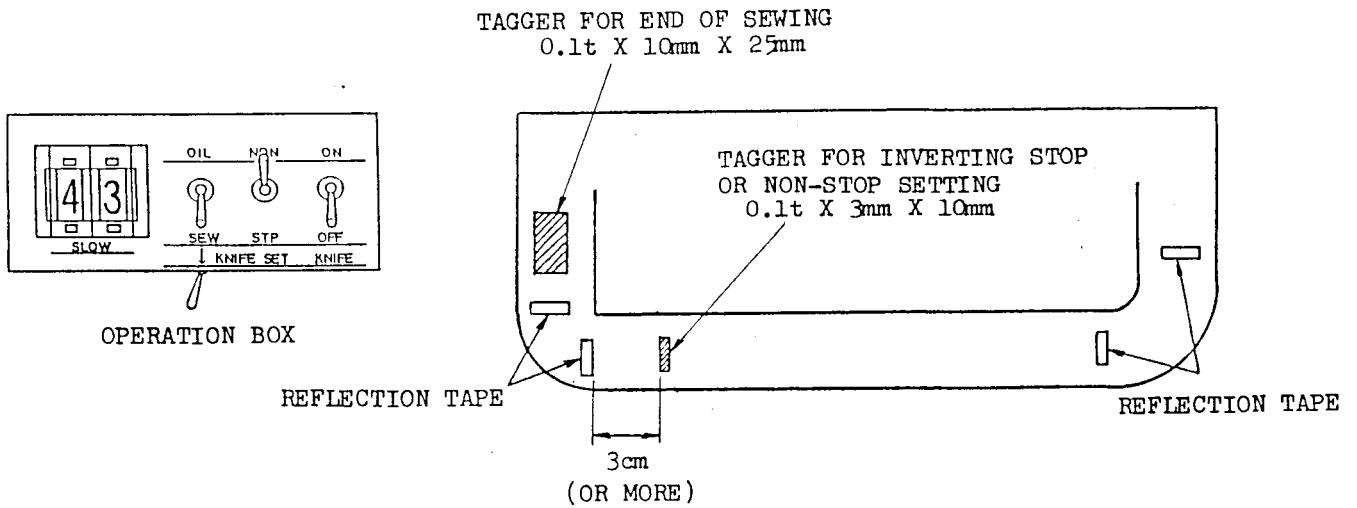

Fig. 11

When sewing at STP side.

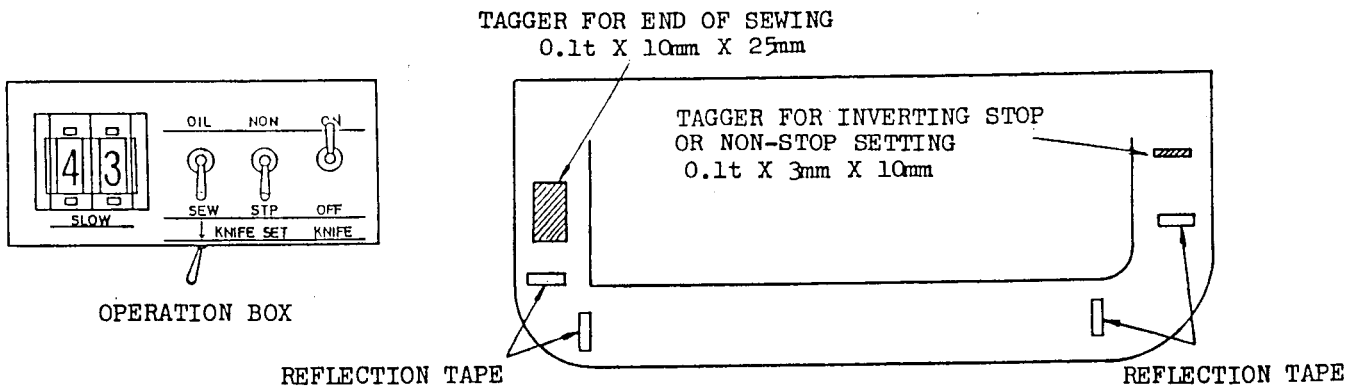

Fig. 12

8) To apply tagger

Tagger for detecting end of sewing operation should be applied as shown in Fig. 13.

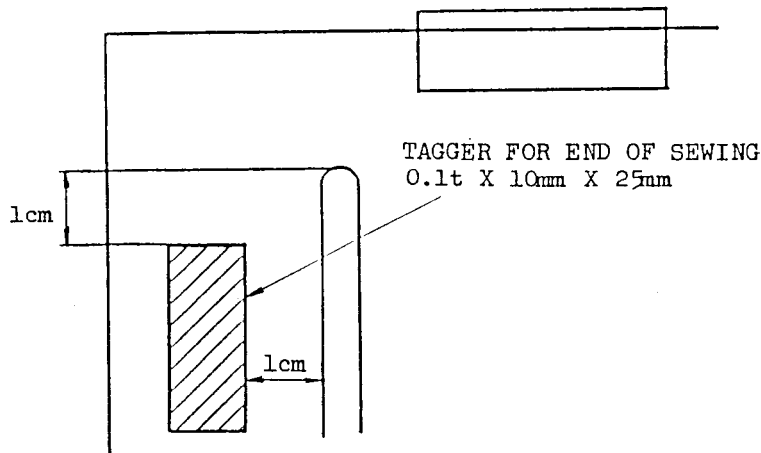

Fig. 13

When it is necessary to apply a tagger for inverting stop or non-stop setting, follow to Fig. 14 shown below.

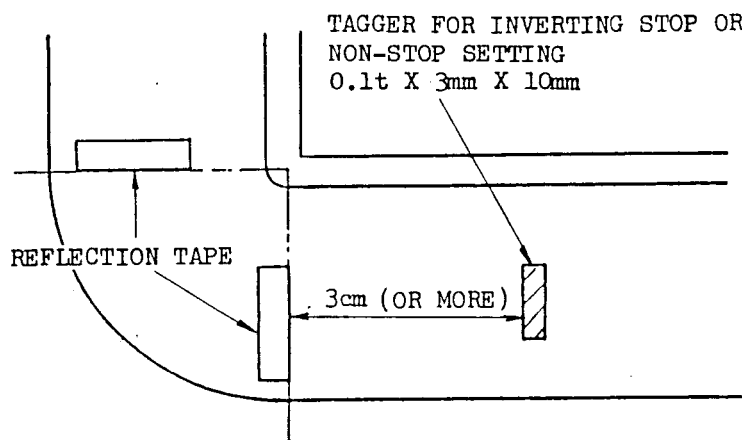

Fig. 14

9) To replace the trimmer knife (see Fig. 15)

Sharpness of the trimmer knife is the key for sewing curved portion and its life is generally one day.

When it is necessary to replace the trimmer knife, turn knife switch to "RELEASE" while the power switch is left to "ON", then the knife moves away from the needle. Loosen knife screw and remove trimmer knife by pulling downward.

Then, inserting new trimmer knife until its upper end reaches to the stopper pin and firmly tighten knife screw.

10) To adjust the trimmer knife (see Fig. 15)

Turn knife switch to "SET" while the power switch is left to "ON", then the knife moves toward the needle. Turn air switch "OFF" so that the knife can be pulled up in its highest position. In this condition, knife should be engaged by 0.5mm with the throat plate boss. If the height should be adjusted, loosen knife holder screw and make the height of the knife by adjusting knife holder up or down.

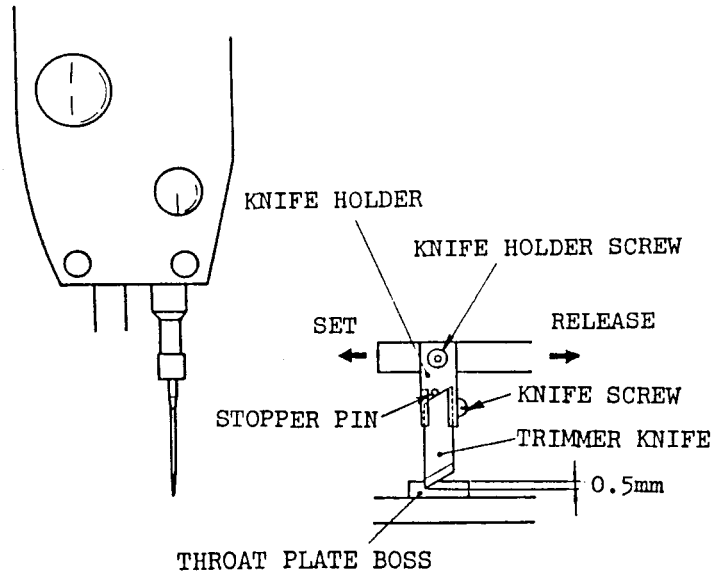

Fig. 15

5. Operation

1) Operation box

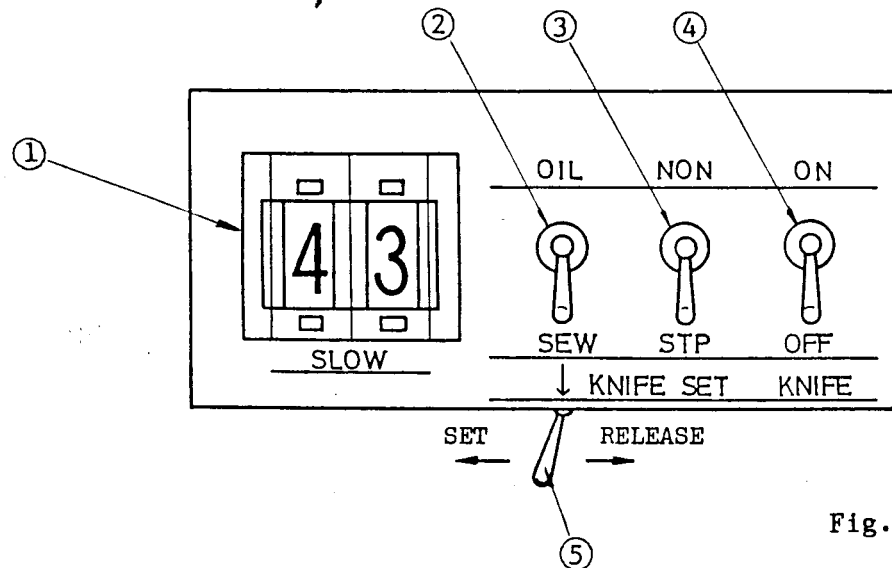

Fig. 16

① Low speed control digital switch

For setting machine speed for sewing curved portion. Normally set this switch to 43-44.

② OIL-SEW change-over switch

When this switch is set to "OIL", machine will run at max. speed.

To give oil to all moving parts, run machine at max. speed for approx. 20 seconds 1-2 times per day without setting patter.

For sewing operation set switch to "SEW".

③ NON-STP change-over switch

Set switch to "NON" to turn pattern at curved portion while sewing.

Set switch to "STP" to stop needle bar at its down position to turn pattern at corners.

④ ON-OFF switch for trimmer knife driving air motor set switch to "ON" and the trimmer knife starts to move.

Set switch to "OFF", then the trimmer knife stops its movement.

⑤ Knife set switch

Turn switch to "SET" and trimmer knife moves to its engaging position for sewing operation.

Turn switch to "RELEASE", then trimmer knife moves away from engaging position for replacing trimmer knife.

2) Test operation

Operate machine to check whether the pattern will move smoothly after applying of reflection tapes and taggers.

① Remove needle and connectors for thread trimmer and backtack from motor control box to avoid possible damage to pattern.

② Check whether regulator indicates 5 kg/cm^2 .

③ Turn on power switch, then presser foot and puller are up automatically.

④ Check whether the machine is correctly adjusted in accordance with instructions under item 4 adjustments.

⑤ Set OIL-SEW switch to "OIL", and depress start/stop switch to check rotating direction of machine pulley. To stop the machine, depress start/stop switch again.

⑥ Select setting of NON-STP switch according to the shape of pattern slot.

⑦ Change-over OIL-SEW switch to "SEW", check knife set switch at "SET" and set knife switch to "ON".

- ⑧ Place pattern on the machine with its starting point in relation to the feeding direction of the machine.
- ⑨ Depress start/stop switch. If pattern does not move smoothly, stop the machine immediately by depressing start/stop switch again.
- ⑩ If pattern moves smoothly, the machine is ready to sew.

6. Maintenance

1) Oiling point

The machine head is lubricated automatically however, oil should be applied to the knee lifting plate shaft and the contact point between plate and plastic end of presser lifter cylinder as shown in Fig. 17.

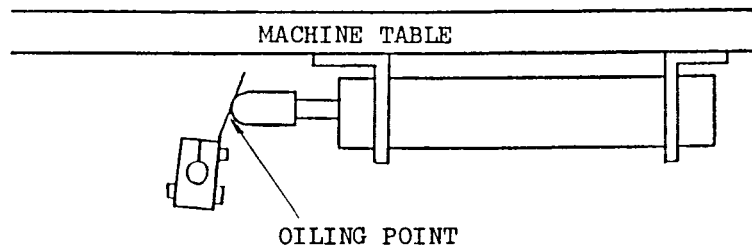

Fig. 17

2) To tilt machine back

Remove mouse plate at first mouse as shown in Fig. 18 and then tilt machine back.

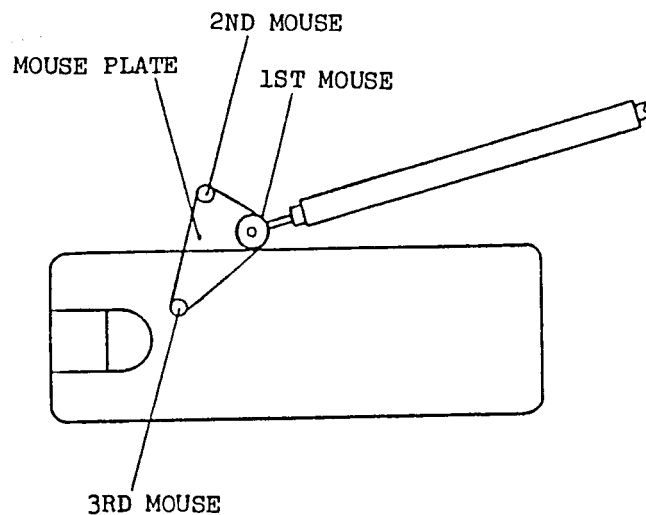

Fig. 18

3) To replace urethane feed dog

If the urethane plate glued on to the feed dog wear out, adjust feed dog height as instructed item 4-4. If the urethane plate wear out and adjustment can not be done, then remove its remaining portion and replace with a new urethane plate.

4) Filter and Regulator

To remove water or oil accumulated at the bottom of the filter and regulator, push the drain cock provided on the underside of the regulator.

5) Lubricator

Lubricator is provided to distribute oil to the air motor for driving trimmer knife.

Oil amount should be adjusted by adjusting screw as shown in Fig. 19.

Use turbine oil (ISO VG32) when filling up or adding oil to the lubricator.

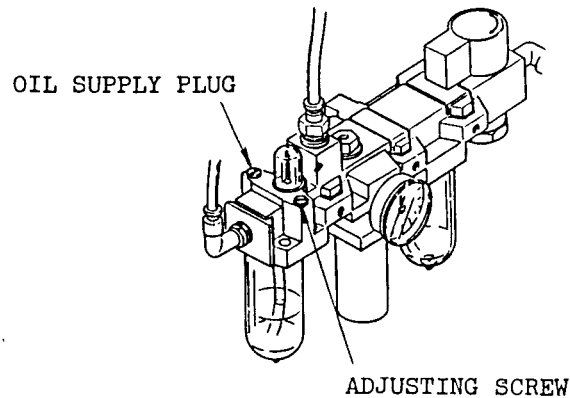

Fig. 19

6) Limit switch

When the mouse cylinder moves to its extreme forward position, the limit switch is activated and makes the mouse cylinder return to its neutral position.