

SINGER

76-1

LIST OF PARTS

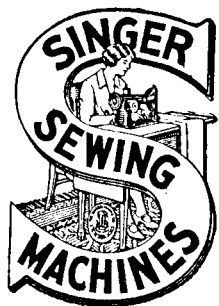

MACHINE No. 76-1

THE SINGER MANUFACTURING COMPANY

INDEX

	PAGE
MACHINE No. 76-1.....	7
NUMERICAL LIST OF PARTS.....	11
OBSOLETE PARTS	9
TUCKER	9

INSTRUCTIONS FOR ORDERING

In ordering from this list, use **ONLY** the part **NUMBER** in the **FIRST** column.

The number stamped on a Sewing Machine part is in every case the number of the single part only.

Every combination of parts sent out as such has its specific number, which, although not stamped on the parts, must be used when ordering the combination.

Each number always indicates the **SAME PART** in whatever list it appears, or for whatever machine.

The letters after some of the numbers indicate the style of finish only, as follows:

- A—Hardened, Polished, Nickel Plated and Buffed
- B—Polished, Nickel Plated and Buffed
- C—Hardened Only
- D—Polished Only
- E—Soft, Not Polished
- F—Hardened and Polished
- H—Blued
- J—Nickel Plated Only
- K—Hardened and Nickel Plated
- L—Brass Plated
- M—Oxidized
- N—Japanned, Dull
- P—Japanned, Bright
- R—Merlized
- T—Copper Plated
- T. A.—Hardened, Polished, Copper and Nickel Plated and Buffed.
- T. B.—Copper and Nickel Plated and Polished.
- T. J.—Copper and Nickel Plated Only.
- T. K.—Hardened, Copper and Nickel Plated.
- T. M.—Copper Plated and Oxidized.
- T. L.—Copper and Brass Plated.
- U—Zinc Plated
- V—Silver Plated
- W—Polished and Nickel Plated
- Z—Chromium Plated
- Z. B.—Polished, Nickel Plated, Buffed and Chromium Plated
- Z. J.—Nickel and Chromium Plated.

These letters **MUST BE USED** when they appear in the list; and **AFTER** the number **as** in the list.

In this series:

- 1 to 1500 and 50001 to 51500 are Screw Numbers.
- 1501 to 1800 and 51501 to 51800 are Nut Numbers.
- 1801 to 2000 and 51801 to 52000 are Roller Numbers.
- 2001 to 50000 and 52001 and upward are numbers of Machine Parts.

The figures in the second column refer only to the plates, illustrating the parts, and are **NOT TO BE USED** in ordering.

Parts marked with an asterisk (*) are furnished only when repairs are made at factory.

When ordering parts which differ as to **Gauge** (the distance between seams) the Gauge, as well as the **Number must be given** on order.

LIST OF PARTS COMPLETE

FOR

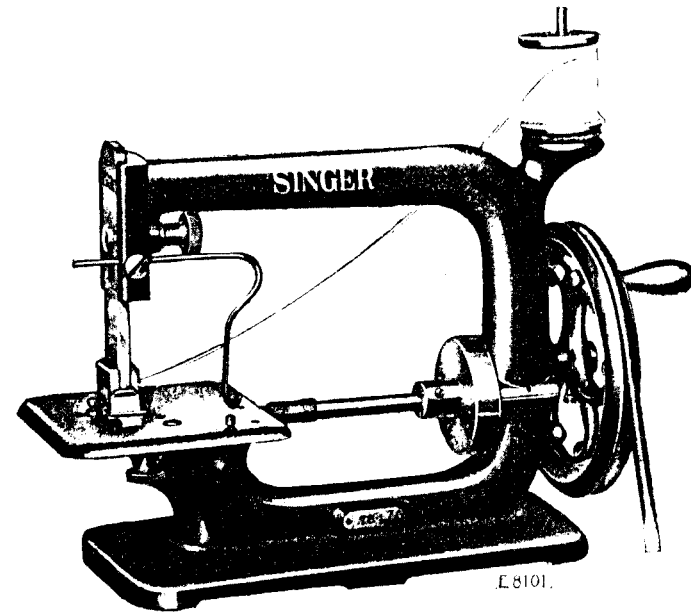

MACHINE No. 76-1

MAKES RUNNING STITCH UPON WHICH THE FABRIC MAY BE GATHERED MORE OR LESS AS DESIRED, OR LEFT FLAT AND NOT GATHERED. HAS STATIONARY NEEDLE UPON WHICH THE FABRIC IS FORCED BY THE CORRUGATED ROLLS. BALANCE WHEEL NO. 39004. DIAMETER OF BELT GROOVE 4½ INCHES.

NO.	PLATE	NAME
*39001	—	Arm, upper and lower (solid).....
39046	4553	“ Shaft.....
39050	—	“ “ 39046 with 1342d, 27414, 39047 and 39048.....
39003	4551	Arm Shaft Gear with 449k.....
449k	4551	“ “ “ Set Screw.....
529b	4551	“ Spool Pin.....
8879	4551	“ “ “ Washer (cloth).....
39004	4550	Balance Wheel with 1229c.....
39005	4551	“ “ Handle (wood).....
1269d	4551	“ “ “ Screw.....
1229c	4551	“ “ Set Screw.....
39006	4551	“ “ Shaft (pinion).....

NO.	PLATE	NAME
39045	4550	Cloth Plate with 911B, 1602E, 35202 and 39011.....
39008	4552	Cloth Plate Pinion (coarse) 7 teeth.....
39009	4552	" " " (fine) 11 teeth.....
39010	4552	" " " Post (left).....
1661B	4552	" " " " Thumb Nut
39011	4552	" " " " (right).....
387A	4551	" " Screw.....
39012	4551	" Spreader.....
911B	4551	" " Screw.....
1617B	4551	" " Thumb Nut.....
39013	4553	Guide.....
759A	4553	" Thumb Screw.....
39014	4552	Pinion (back) coarse, 7 teeth.....
39015	4552	" " fine, 11 teeth.....
39041	4553	" (front) coarse, 7 teeth.....
39042	4553	" " fine, 11 teeth.....
39014	4552	" (intermediate) coarse, 7 teeth.....
39015	4552	" " fine, 11 teeth.....
39021	4552	" Bar.....
39049	—	" " 39021 with 211D, 560B, 39024, 39025, 39051 and two 174B.....
39022	—	Pinion Bar (coarse) complete, Nos. 665D, 39018, 39041, 39049 and two 39014....
39023	—	Pinion Bar (fine) complete, Nos. 665D, 39018, 39042, 39049 and two 39015....
39024	4552	Pinion Bar Cap (left).....
39025	4552	" " " (right).....
174B	4552	" " " Screw.....
1268B	4552	" " Clamping Stud.....
1660B	4552	" " " Thumb Nut.....
39026	4552	" " " " Washer
560B	—	" " Regulating Thumb Screw....
39018	4552	" Shield.....
665D	4552	" " Screw.....
39027	4552	Roller (coarse) 18 teeth, with 39040.....
39028	4552	" (fine) 29 teeth, with 39040.....
39040	4552	" Key.....
39047	4553	" Shaft.....
39048	4553	" " Sleeve.....
1342D	4553	" " " Screw.....
27414	4552	" " Spring.....

FOR TWO NEEDLES, FOR $\frac{5}{32}$ IN. GAUGE

39032	4553	Cloth Plate Pinion (coarse) 7 teeth.....
39033	4553	" " " (fine) 11 teeth.....
39034	4553	Pinion (back) coarse, 7 teeth.....

NO.	PLATE	NAME
39035	4553	Pinion (back) fine, 11 teeth.....
39043	4553	" (front) coarse, 7 teeth.....
39044	4553	" " fine, 11 teeth.....
39034	4553	" (intermediate) coarse, 7 teeth.....
39035	4553	" " fine, 11 teeth.....
39036	—	Pinion Bar (coarse) complete, Nos. 665D, 39018, 39043, 39049 and two 39034....
39037	—	Pinion Bar (fine) complete, Nos. 665D, 39018, 39044, 39049 and two 39035....
39038	4553	Roller (coarse) 18 teeth, with 39040.....
39039	4553	" (fine) 29 teeth, with 39040.....

TUCKER (Long Arm)

NO.	PLATE	NAME
35201	4555	Edge Guide.....
35202	4555	" " Guide Pin for 39045.....
26569	4554	" " Slide.....
703D	4555	" " " Thumb Screw.....
7071	4555	" " " " Washer.
35203	—	Edge Guide complete, Nos. 703D, 7071, 26569 and 35201.....
26570	4554	Tuck Guide Plate.....
26571	4554	" " " Arm with 5944.....
58D	4555	" " " " Hinge Screw.....
35221	4554	" " " Bracket.....
732D	4555	" " " " Thumb Screw
5944	4555	" " " Guide Pin.....
287D	4555	" " " Thumb Screw.....
7071	4555	" " " " " Washer.
35222	—	Tucker Guide Plate complete, Nos. 58D, 287D, 732D, 7071, 26570, 26571, 35221 and two wood screws 1 in. No. 12....
35204	—	Tucker complete, Nos. 35203 and 35222..

OBSOLETE PARTS

NO.	PLATE	NAME
39002	4551	Arm Shaft for 14026.....
39007	4550	Cloth Plate with 911B and 39011, use 39045
39029	4553	Roller Pin for 39027, 39028, 39038 and 39039.....
39030	4552	Roller Shaft.....
39031	4552	" " Sleeve.....
14026	4552	" " " Pin.....

PLATE 4550 --ONE-HALF SIZE

39004

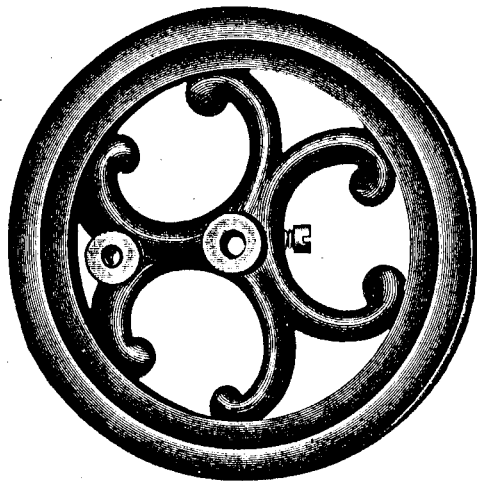

39007

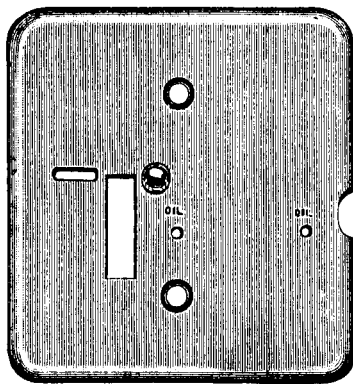

39045

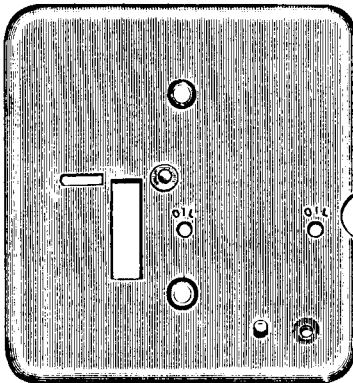

PLATE 4551—FULL SIZE

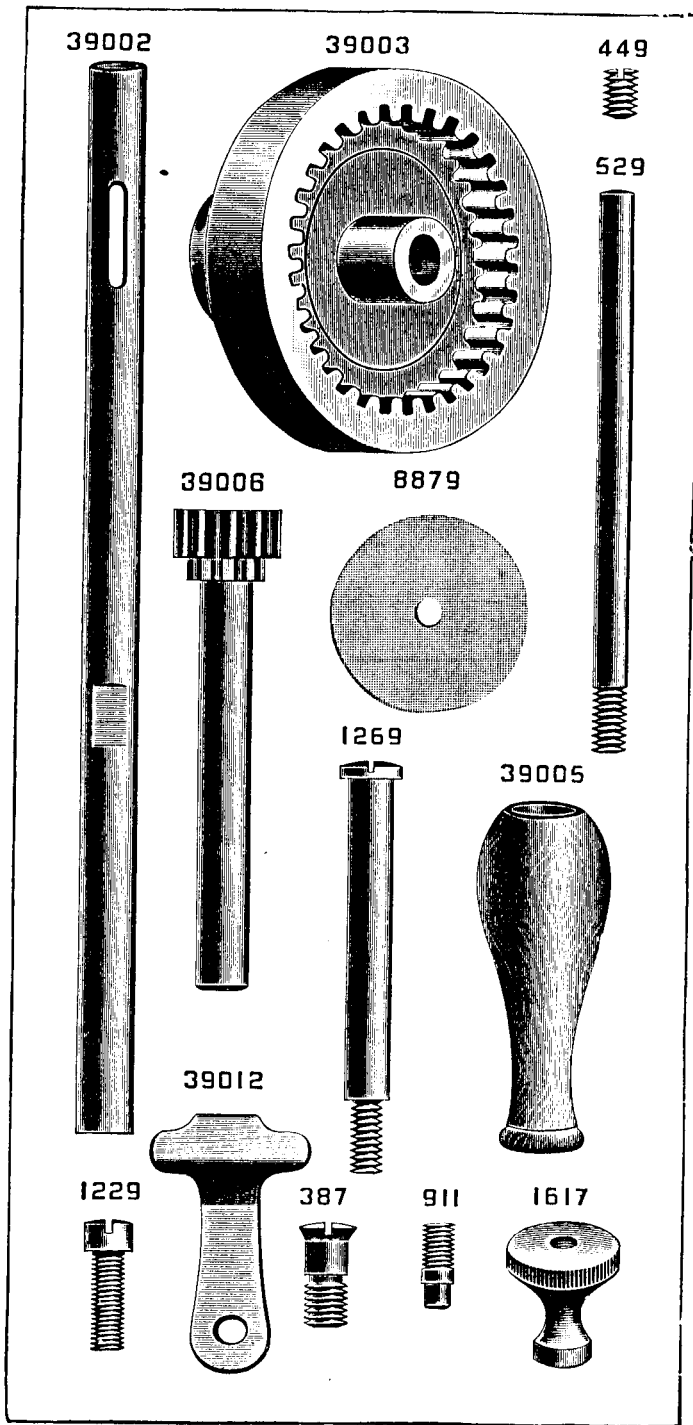

PLATE 4552—FULL SIZE

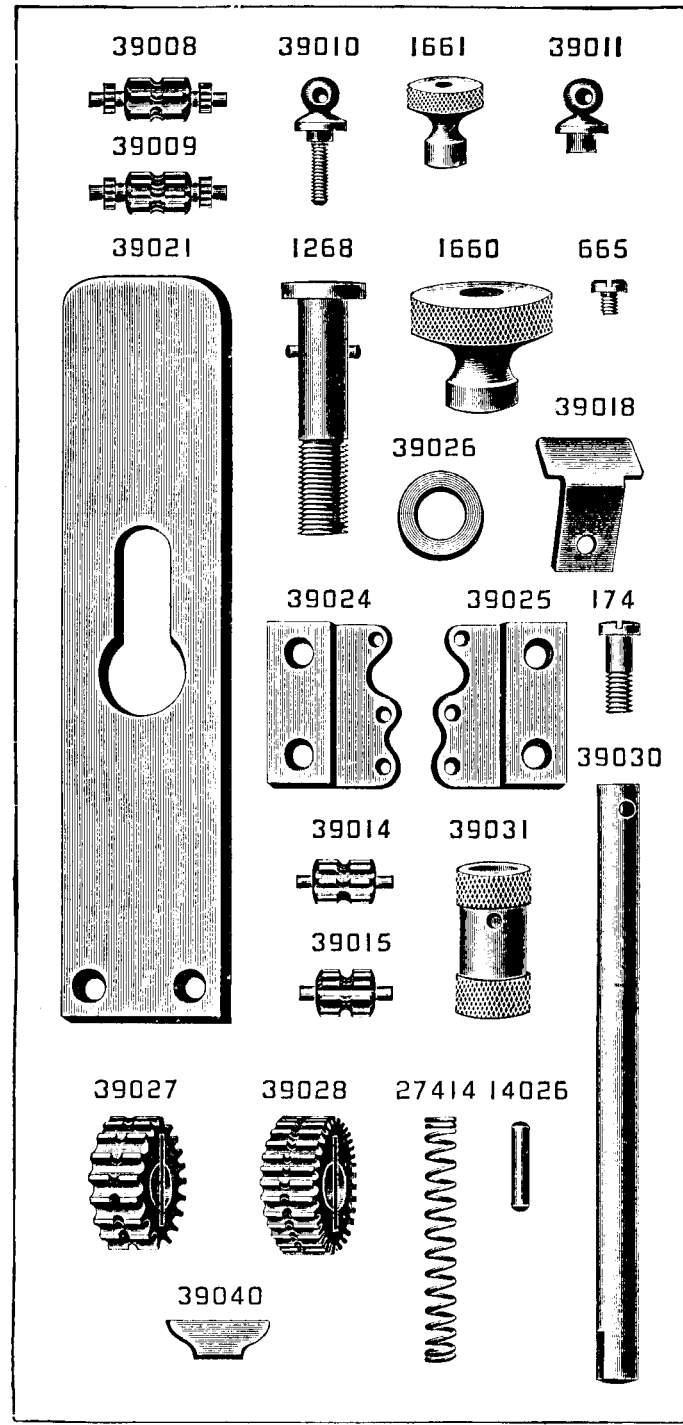

PLATE 4553—FULL SIZE

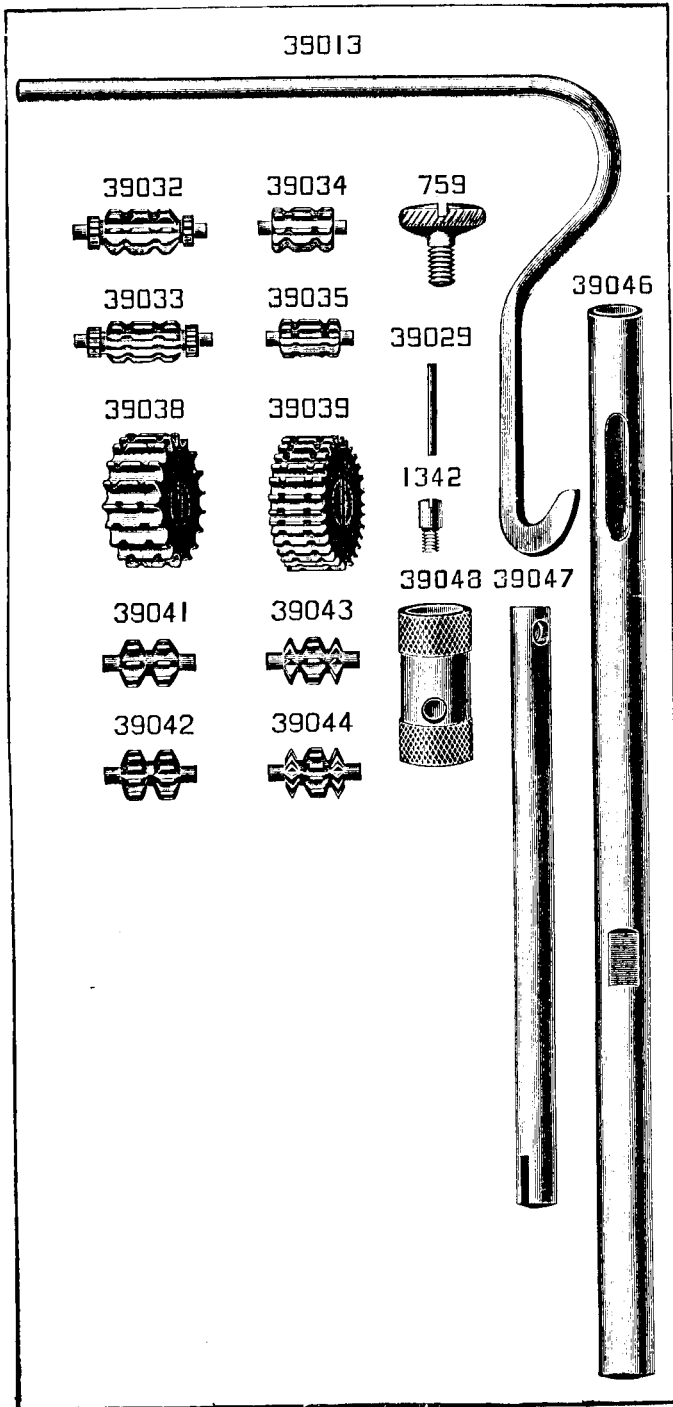

PLATE 4554—ONE-FOURTH SIZE

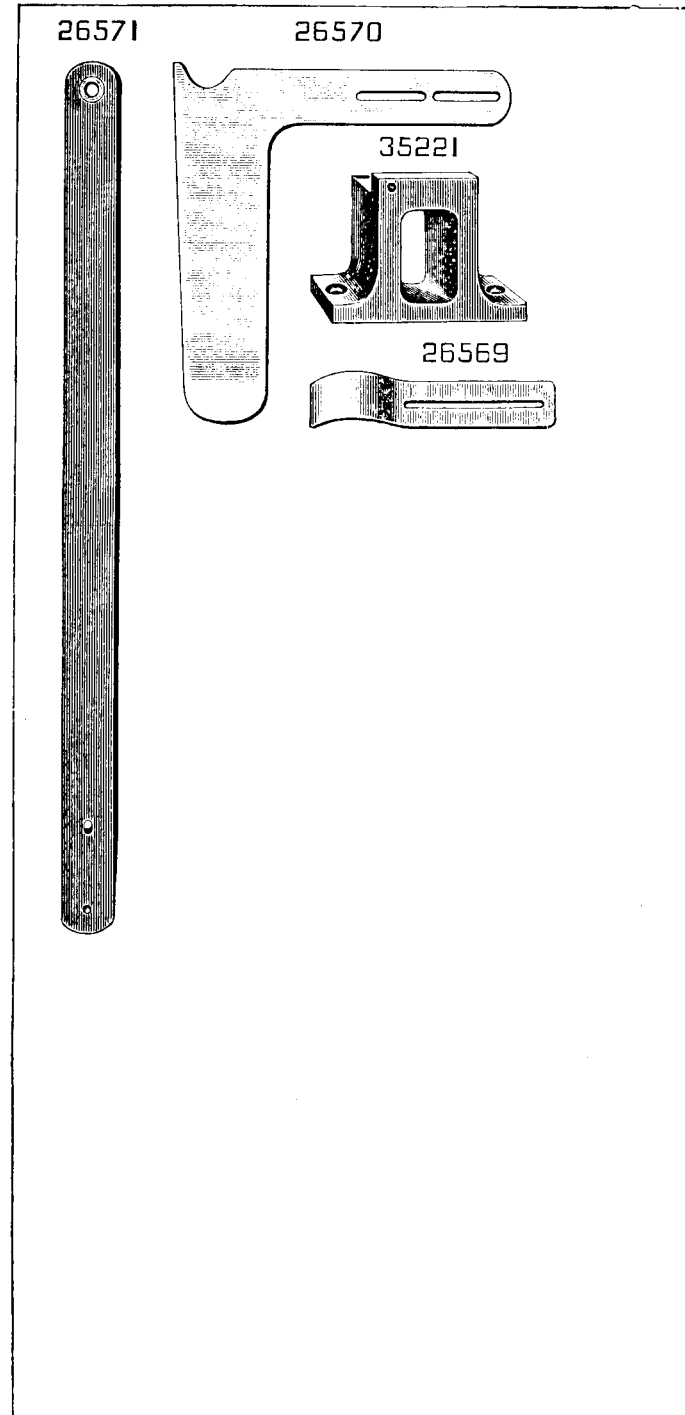
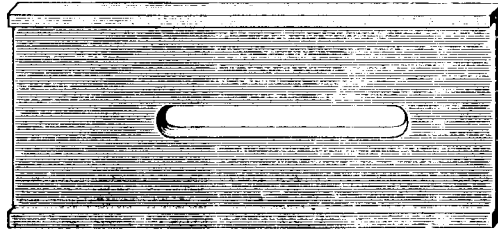

PLATE 4555—FULL SIZE

35201



35202



5944



703



732



287



58

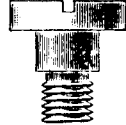

7071

