

# **Service Manual**

# **SINGER\***

20u31 / 33 / 35

MACHINES

## CONTENTS

	Page
Description . . . . .	1
Sewing Defects and Adjustments . . . . .	2
To Set Needle Bar at Correct Height . . . . .	3
Relation Between Needle and Rotating Hook . . . . .	4
To Adjust Sidewise Movement of Needle while in the Material (Zigzag Stitching) . . . . .	5
To Adjust Needle Location in Relation to Needle Hole in Throat Plate . . . . .	6
To Obtain Uniform Straight Stitch . . . . .	14
To Set Feed Dog at Correct Height . . . . .	14
To Centralize Feed Dog in Throat Plate Slots . . . . .	15
To Set Presser Bar at Correct Height . . . . .	17
Timing the Feed . . . . .	18
Positioning the Feed and Feed Lifting Eccentric, Feed Forked Connection, Feed Rock Shaft Crank, Feed Lifting Rock Shaft Crank Connecting Rod and Feed Lifting Rock Shaft Crank . . . . .	20
Adjustment of Tension . . . . .	20
Adjustment of Backlash . . . . .	22

## DESCRIPTION

Model 20U artisan machine produces top quality straight and zigzag stitches in fabrics as fine as ladies' lingerie or as heavy as overcoating.

### GENERAL FEATURES

- \* Rotating hook
- \* Link take-up
- \* Stitch length controlled by feed regulating dial
- \* Needle position selector places stitching in left, center or right needle positions
- \* Spring biased stitch width selector which can also be set at desired stitch width

### SPECIFICATIONS

* Maximum stitch width	9mm
* Maximum stitch length	5 s.p.i. (5 stitches/25.4 mm)
* Needle bar stroke	34.8 mm
* Height of presser foot from top surface of throat plate	6.35 mm
* Thread take-up lever stroke	63.5 mm
* Needle bar height (Distance from throat plate seat to needle stop in needle bar at its lowest position)	25.07 mm
* Speed - up to 5 mm stitch width	2,500 r.p.m.
over 5 mm and up to maximum stitch width	2,000 r.p.m.
* Diameter of machine pulley (for motor drive)	75 mm (3 in.)

SEWING DEFECTS AND ADJUSTMENTS

Place of Adjustment	Sewing Defects									
	Needle Breakage	Thread Breakage	Skip Stitching	Looping, Stagger & Hitch Stitch	Improper Feeding	Puckering	Uneven Zigzag Stitches	Noise		
1. Thread	-	X	X	X	-	X	-	-	-	-
2. Needle	X	X	X	X	-	X	X	-	-	-
3. Needle Bar	X	X	X	-	-	-	-	-	-	X
4. Rotating Hook	-	X	X	-	-	-	-	-	-	X
5. Bobbin Case	-	X	-	X	-	X	-	-	-	-
6. Needle Thread Tension	-	X	-	X	X	X	X	-	-	-
7. Thread Take-up Lever	-	X	-	-	-	-	-	-	-	X
8. Presser Foot	X	X	X	-	X	X	-	-	-	-
9. Feed	-	-	-	-	X	X	-	-	-	X
10. Throat Plate	X	X	-	-	X	-	-	-	-	-
11. Stitch Width	X	-	-	-	-	-	-	-	-	-
12. Needle Position	X	-	-	-	-	-	-	-	-	-
13. Material	X	-	-	-	-	X	X	-	-	-
14. Gear	-	-	-	-	-	-	-	-	-	X

## TO SET NEEDLE BAR AT CORRECT HEIGHT

### CHECK:

1. Remove face plate.
2. Set needle position selector on "center" and stitch width regulator for straight stitching.
3. Turn machine pulley over toward you until needle descends to its lowest position.
4. Check whether upper timing mark on needle bar is level with underside of needle bar timing indicator plate.

CAUTION: The needle bar timing indicator plate has been correctly positioned at the factory and it SHOULD NOT BE DISTURBED.

### ADJUSTMENT:

If needle bar is not set at correct height, then adjustment should be made as instructed below.

1. With machine set for straight stitching at center needle position, turn machine pulley until needle bar is at its lowest position.
2. Loosen needle bar set screw so that only the needle bar will move up and down freely.
3. Move needle bar up or down as required, and align its upper timing mark with underside of needle bar timing indicator plate. Then securely tighten needle bar set screw.
4. Replace face plate.

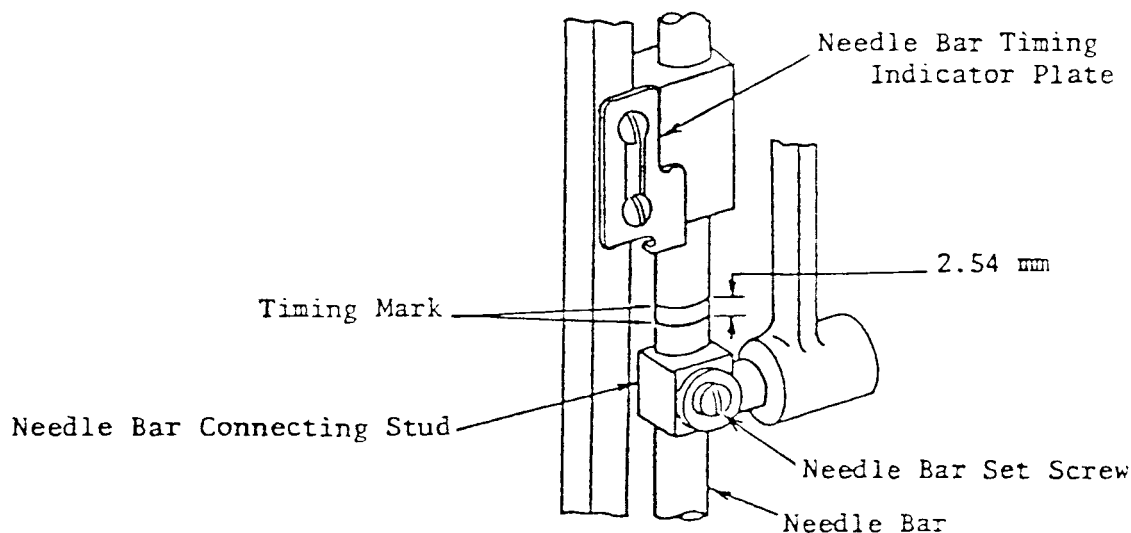

Fig. 1

## RELATION BETWEEN NEEDLE AND ROTATING HOOK

### A. TO TIME THE ROTATING HOOK

#### CHECK:

1. Set needle position selector on "center" and stitch width regulator for straight stitching.
2. Turn machine pulley over toward you until needle rises 2.54 mm from its lowest position and the lower timing mark is level with the underside of needle bar timing indicator plate. When the needle bar is in the above position, the point of rotating hook should be at the center of the needle as shown in Fig. 2.

#### ADJUSTMENT:

If the timing of rotating hook in relation to the needle requires correction, make adjustments as instructed below.

1. Set machine for straight stitching at center needle position.
2. Remove rotating hook shaft bevel gear cover.
3. Loosen two rotating hook set screws and adjust rotating hook as required. Retighten set screws.

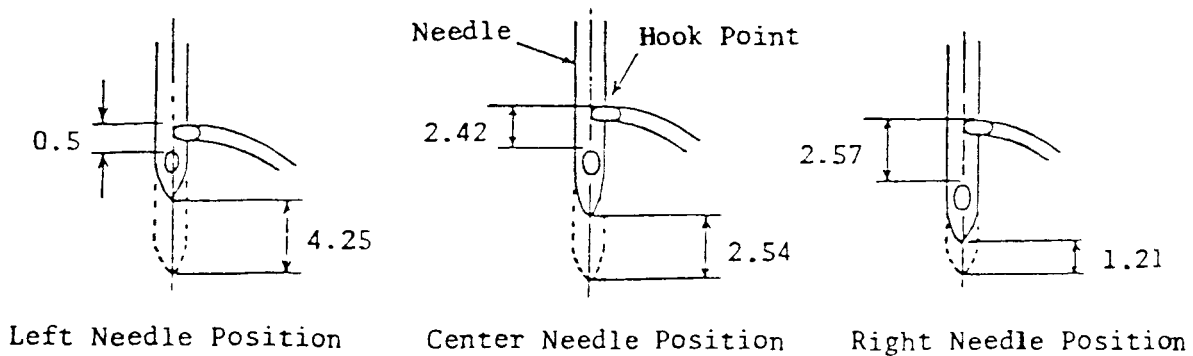

Fig. 2

### B. CHECK TIMING OF ROTATING HOOK AND NEEDLE (AT LEFT, CENTER AND RIGHT NEEDLE POSITIONS)

1. Turn machine pulley over toward you and make sure the needle is free from any interference when it is swung from minimum to maximum bight at left, center and right needle positions.

2. Set stitch width regulator for straight stitching and check (visually) whether the relationship between needle and rotating hook is as shown in Fig. 2 (at center and left needle positions) just when needle rises from its lowest position.
3. Be sure the clearance between needle and hook point is 0 - 0.05 mm (Fig. 3) regardless of left, center, or right needle positions. Excessive clearance may result in skip stitching. Adjustment should be made in the same way as explained in paragraph A, "TO TIME THE ROTATING HOOK".

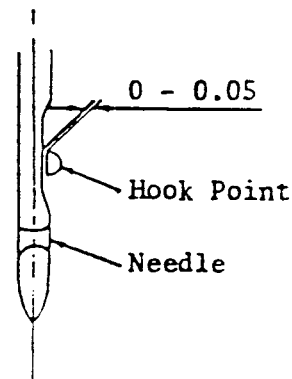

Fig. 3

TO ADJUST SIDewise MOVEMENT OF NEEDLE  
WHILE IN THE MATERIAL (ZIGZAG STITCHING)

When zigzag stitching, the needle must not move sidewise while its point is still in the material, or in the needle hole in throat plate. The needle should make its upward or downward movement only after completing its swing to the left or right as shown in Fig. 4.

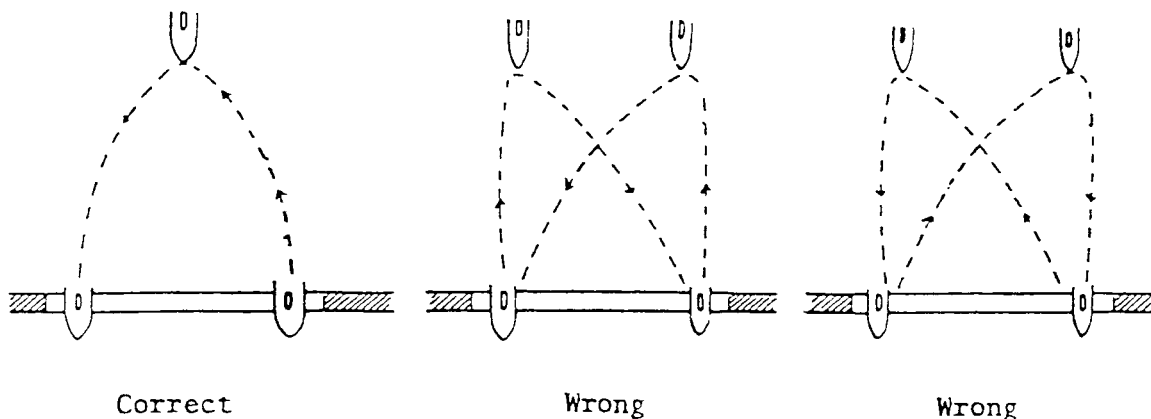

Fig. 4

Fig. 5-a

Fig. 5-b

If the needle continues its swing even as it enters the needle hole in throat plate, or when it begins to rise as shown in Fig. 5-a and 5-b, such condition should be corrected by making the following adjustments.

ADJUSTMENT:

1. Turn machine pulley over toward you until needle bar is at its lowest position.
2. Remove screws and lift off arm top cover. Loosen the zigzag triangular cam shaft collar set screw and slide collar toward front of machine. Check whether the two zigzag triangular cam set screws (with center line aligned) are located parallel to the bearing face of the zigzag stitch regulator fork.
3. If the triangular cam set screws are not located parallel to the bearing face of the stitch regulator fork, loosen arm shaft (horizontal) worm gear set screws and turn arm shaft worm gear as required until the triangular cam set screws are in either one of the two positions shown in Fig. 6. Then securely tighten arm shaft worm gear set screw.
4. Check with a dial gage (Fig. 11) to see whether the needle is still making sidewise movement while in the fabric and below throat plate, and if necessary, readjust as instructed above.

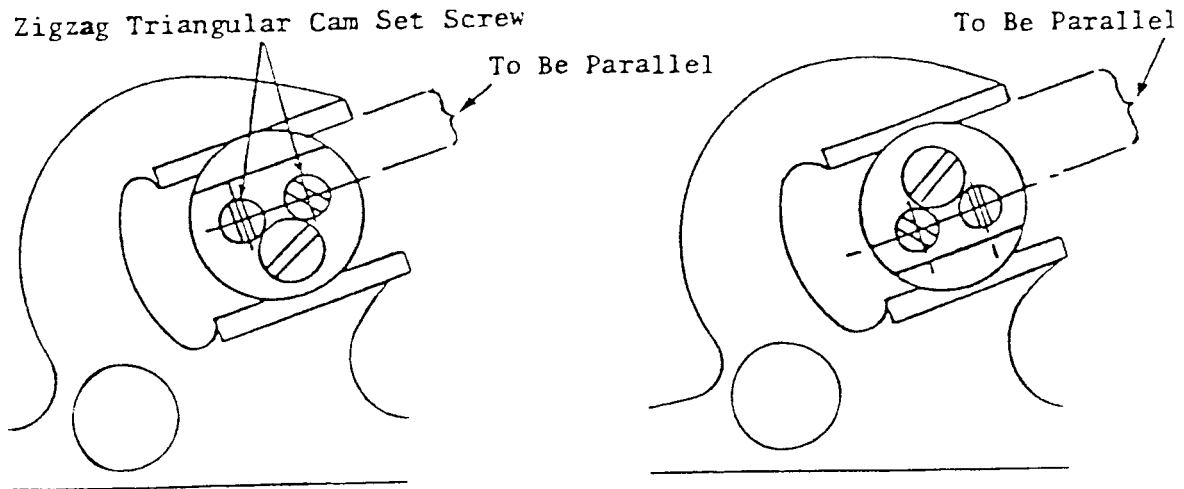

Fig. 6

TO ADJUST NEEDLE LOCATION IN  
RELATION TO NEEDLE HOLE IN THROAT PLATE

CHECK:

1. Fit needle to needle clamp. (Make sure the needle is not bent.)
2. Set needle position selector on "center" and stitch width regulator for straight stitching.



4. Turn machine pulley slowly until needle descends into the needle hole in throat plate (for zigzag stitching) and check whether or not the needle is properly located in the center of the needle hole (Fig. 7).
5. Change throat plate to straight stitching throat plate, lower needle into needle hole and check whether it is properly centered or not. Change throat plate to zigzag stitching throat plate.
6. Move stitch width regulator to maximum stitch width and while holding regulator in this position, turn machine pulley and check left and right needle locations in relation to the center of needle hole in throat plate. Also check left and right needle locations in relation to the needle hole with needle position set at left and right of center.

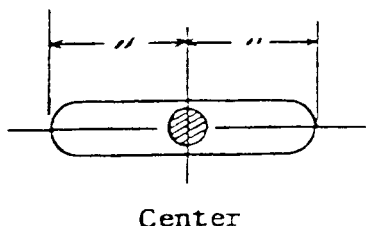

Fig. 7

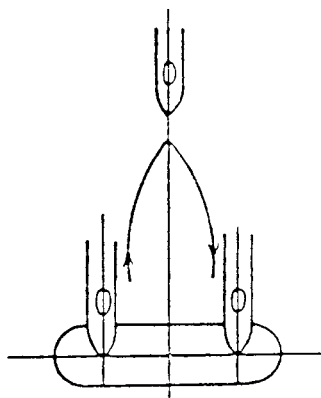

Fig. 8

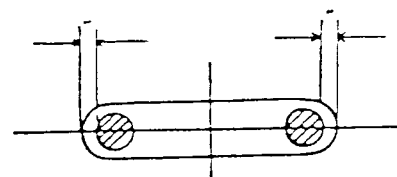

Fig. 9

#### ADJUSTMENT:

If the needle location is offset to the left or to the right of center and the clearance between needle and edge of hole at left and right is not equal, or if needle continues to swing even when machine is set for straight stitching, and if for any reason it is necessary to replace and adjust related parts, then adjust as instructed below.

#### A. TO ELIMINATE SIDEWISE MOVEMENT OF NEEDLE WHEN MACHINE IS SET FOR STRAIGHT STITCHING

1. Fit needle plug to needle clamp. (Make needle plug by grinding down the point of a needle.)

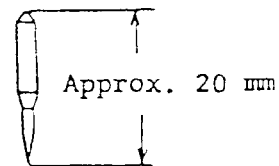

Fig. 10

2. Loosen and remove arm side cover screws and remove side cover. Remove arm top cover screws and lift off top cover.
3. Set needle position selector on "center" and stitch width regulator for straight stitching.
4. Turn machine pulley over toward you and check existence of sidewise movement of needle. (Fig. 11)
5. If there is a sidewise movement in the needle, loosen bight amplitude stop plate (left) set screw and move left bight amplitude stop plate (marked with asterisk) to the left or right as required, until the sidewise movement is eliminated. (Fig. 12)

Check, using a dial gage (Fig. 11), and make sure the sidewise movement (if any) is held to less than 0.05 and securely tighten set screw.

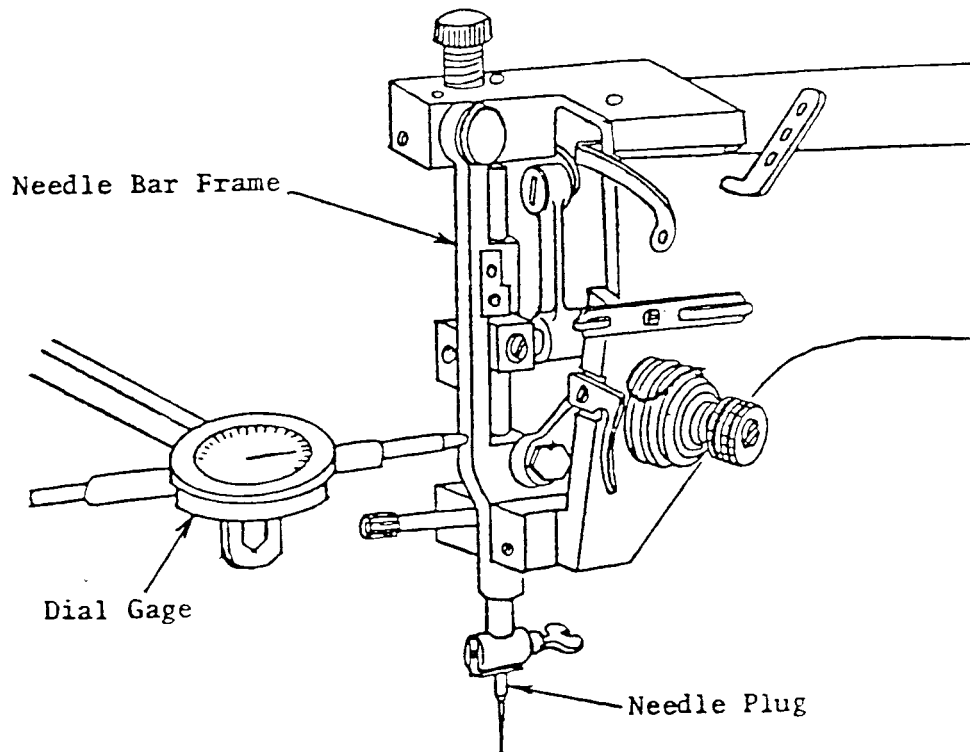

Fig. 11

BIGHT AMPLITUDE REGULATOR AND NEEDLE POSITION  
SELECTOR MECHANISMS VIEWED FROM BACK OF MACHINE

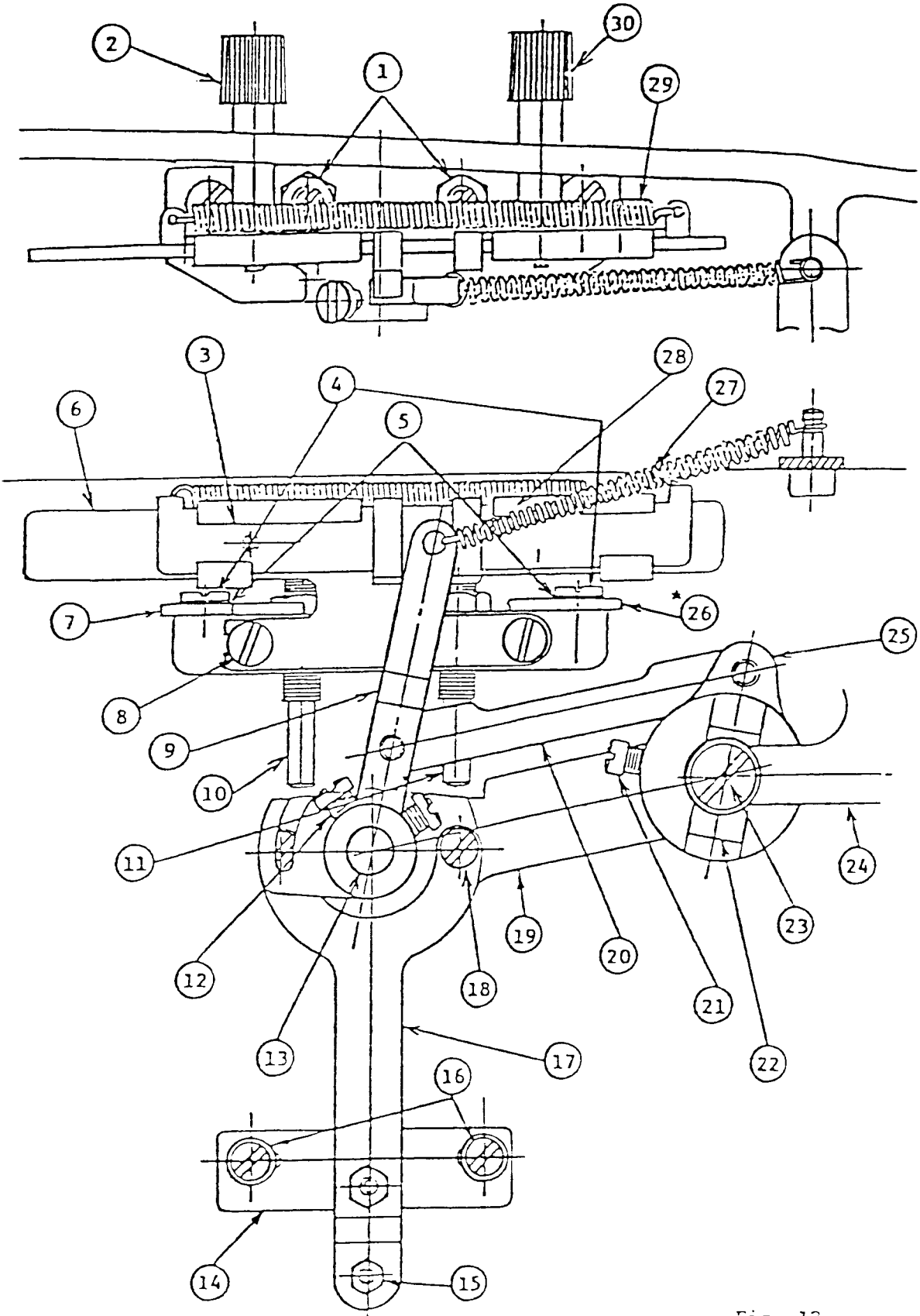

Fig. 12

Ref. No.Description

1. Bight and Needle Position Lever Arm Regulating Screw Nut (left and right)
2. Bight Amplitude Regulating Plate (right) Thumb Screw
3. Bight Amplitude Regulating Plate (right)
4. Bight Amplitude Stop Plate (left and right) Screw
5. Bight Amplitude Stop Plate (left and right) Washer
6. Bight Amplitude Regulating Plate Holder
7. Bight Amplitude Stop Plate (right)
8. Bight Amplitude Regulating Plate Holder Screw
9. Bight Amplitude Slide Block Crank
10. Bight and Needle Position Lever Arm Regulating Screw (right)
11. Bight and Needle Position Lever Arm Regulating Screw (left)
12. Bight Amplitude Slide Block Crank Set Screw
13. Bight Amplitude Slide Block Crank Shaft
14. Bight and Needle Position Block
15. Bight and Needle Position Lever Thumb Stud Nut
16. Bight and Needle Position Block Set Screw
17. Bight and Needle Position Lever
18. Bight and Needle Position Lever Set Screw
19. Bight and Needle Position Lever Arm
20. Bight Amplitude Slide Block Crank Link
21. Bight Amplitude Slide Block Guide Stud Set Screw
22. Bight Amplitude Slide Block
23. Bight Amplitude Slide Block Cap Screw
24. Zigzag Stitch Regulator Fork
25. Bight Amplitude Slide Block Guide
26. \* Bight Amplitude Stop Plate (left)
27. Bight Amplitude Slide Block Crank Spring
28. Bight Amplitude Regulating Plate (left)
29. Bight Amplitude Regulating Plate Spring
30. Bight Amplitude Regulating Plate (left) Thumb Screw

6. Lower needle into needle hole in throat plate and check whether the needle is properly centered in the needle hole.
7. If needle is not properly centered in the needle hole, check whether the notch on the hexagon head of the zigzag stitch regulator fork eccentric connection pin (Fig. 15) is located at top, then loosen bight and needle position block set screw and adjust bight and needle position block to the left or right as required. Securely tighten the set screw.
8. Turn machine pulley and check existence of sidewise movement of needle. If it is found necessary to make readjustment, it should be made as instructed in item 5, page 8.

#### B. ADJUSTMENT TO OBTAIN MAXIMUM ZIGZAG STITCH WIDTH (9 mm)

1. Set needle position selector on "center" needle position and stitch width regulator for maximum stitch width.
2. Place a light card under presser foot, turn machine pulley and make light needle punctures in the card and check width of zigzag stitch.
3. If maximum stitch width of 9 mm can not be obtained with machine set as instructed above, loosen bight amplitude stop plate (right) screw and move bight amplitude stop plate (right) to the left or right as required. Then securely tighten set screw.

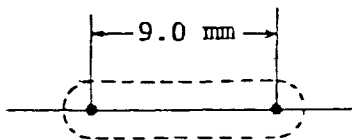

Fig. 13

#### C. SETTING THE CENTER NEEDLE POSITION

1. Set needle position selector on "center" needle position and stitch width regulator for straight stitching. Place a light card under presser foot, turn machine pulley and make a needle puncture on the card. Then set stitch width regulator for maximum stitch width, make needle punctures on the card in the same way as above and check whether the left and right needle punctures are equally distanced from the center.

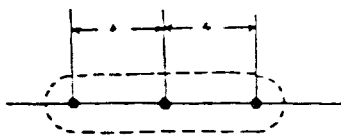

Fig. 14

2. If left and right needle locations are not equidistant from the center, loosen bight and needle position block set screw and move bight and needle

position block to the left or right as required. Securely tighten set screw when correct needle location is obtained.

If correct needle locations cannot be obtained by making the above adjustment, then the bight and needle position lever and bight and needle position lever arm should be adjusted as follows.

- a. Loosen bight amplitude slide block crank set screw and remove bight amplitude slide block crank shaft in order to move bight amplitude slide block crank out of the way to make adjustments.
- b. Loosen the two bight and needle position lever set screws and adjust bight and needle position lever in relation to bight and needle position lever arm. After making the adjustment, securely tighten the two set screws.
- c. Replace bight amplitude slide block crank shaft, set bight amplitude slide block crank in proper position and securely tighten the slide block crank set screw.

If needle position selector is not in alignment with the marking on front of the arm standard, readjust bight and needle position block in the same way as instructed above.

#### D. SETTING THE LEFT NEEDLE POSITION

1. Set needle position selector on "left" needle position and turn machine pulley to bring needle to its lowest position.
2. Move stitch width regulator to maximum bight a few times and check to see that sidewise movement of needle is within 1 - 2 mm. If needle makes a full 9 mm swing, turn machine pulley over toward you one complete turn, that is, raise needle to the top once and bring it down to its lowest position again, then check sidewise movement of needle as instructed above.
3. If needle makes a slight sidewise movement when stitch width regulator is moved to its maximum bight, this should be corrected as follows.

Loosen bight and needle position lever arm regulating screw nut (right) and turn bight and needle position lever arm regulating screw (right) clockwise or counterclockwise, as required, and temporarily tighten set screw.

Make certain the sidewise movement of needle is less than 0.1 mm, then securely tighten set screw.

#### E. SETTING THE RIGHT NEEDLE POSITION

1. Set stitch width regulator for straight stitching and needle position selector on "left" needle position. Place a light card under presser foot, turn machine pulley and make a needle puncture on the card in the same way as above and measure distance between left and right needle locations.

2. If there is **not** a 9.0 mm distance between the left and right needle locations, **loosen** bight and needle position lever arm regulating screw nut (left) and **turn** bight and needle position lever arm regulating screw (left) clockwise or counterclockwise, as required, and retighten set screw.

#### F. FINAL ADJUSTMENT OF NEEDLE LOCATION

1. Check needle location in relation to the needle hole in throat plate at maximum bight in left, center and right needle positions.
2. Remove general purpose throat plate and replace with throat plate for straight stitching. Set needle position selector on "center" needle position and stitch width regulator for straight stitching. Then lower needle into hole in throat plate and check needle location.
3. If the needle location in relation to the needle hole in throat plate need to be adjusted, loosen zigzag stitch regulator fork eccentric connection pin set screw (Fig. 15) and turn zigzag stitch regulator fork eccentric connection pin, as required, to obtain correct needle location.
4. Make certain that needle is correctly located, and securely tighten set screw. Then change straight stitch throat plate to general purpose throat plate.

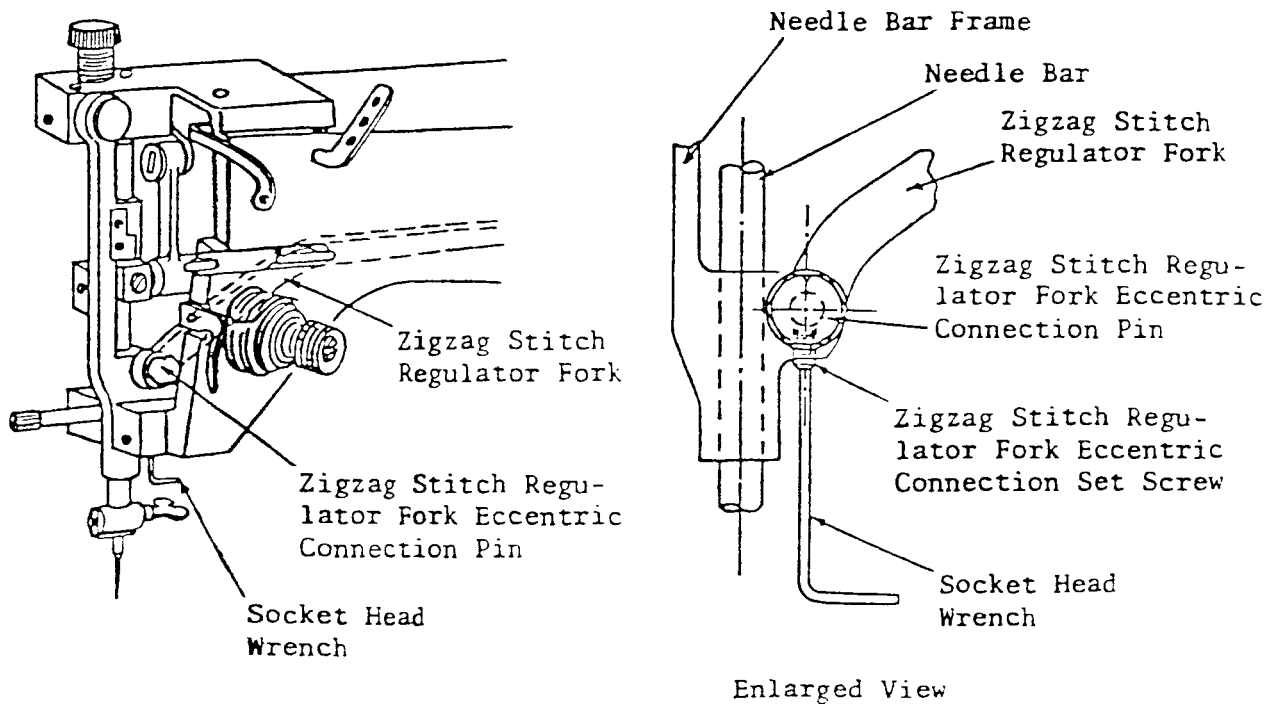

Fig. 15

## TO OBTAIN UNIFORM STRAIGHT STITCH

The position of bight amplitude stop plate (left) requires adjustment if the machine produces uniform straight stitches when stitch width regulator is still located slightly in front of the zero position (just before regulator is located completely on zero position) or when the machine produces a staggered or uneven stitches even when the stitch width regulator is set at zero position for straight stitching.

To make the above adjustment, follow the instruction given on page 7 under "TO ELIMINATE SIDEWISE MOVEMENT OF NEEDLE WHEN MACHINE IS SET FOR STRAIGHT STITCHING"

## TO SET FEED DOG AT CORRECT HEIGHT

When feed dog is at its highest position, the teeth should project 1.02 - 1.09 mm above the top surface of the throat plate.

If feed dog is set too low, proper stitch length can not be obtained due to improper feeding of the material, and when set too high, it may interfere with the underside of the throat plate. These conditions should be corrected by making the following adjustments.

### ADJUSTMENT:

1. Raise presser foot and turn machine pulley over toward you to bring feed dog to its highest position above throat plate.
2. Loosen feed lifting rock shaft crank clamping screw and turn feed lifting rock shaft toward you or away from you, as required. Then securely tighten clamping screw when correct height is obtained.

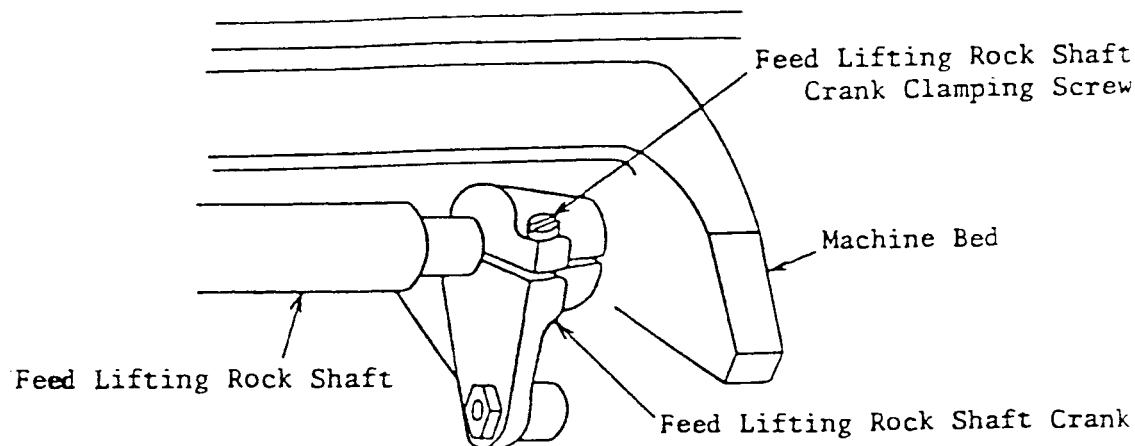

Fig. 16



## TO CENTRALIZE FEED DOG IN THROAT PLATE SLOTS

Feed dog should not contact edges of throat plate slots during its movement but should be located centrally in relation to the front, rear and sides of throat plate slots.

Before making any unnecessary adjustments to the feed dog, check that it lies parallel to the throat plate slots.

### LENGTHWISE SETTING:

1. Set machine for maximum stitch length.
2. Loosen feed rock shaft crank clamping screw (Fig. 17) and move feed bar and feed rock shaft, as required.
3. Securely tighten clamping screw.

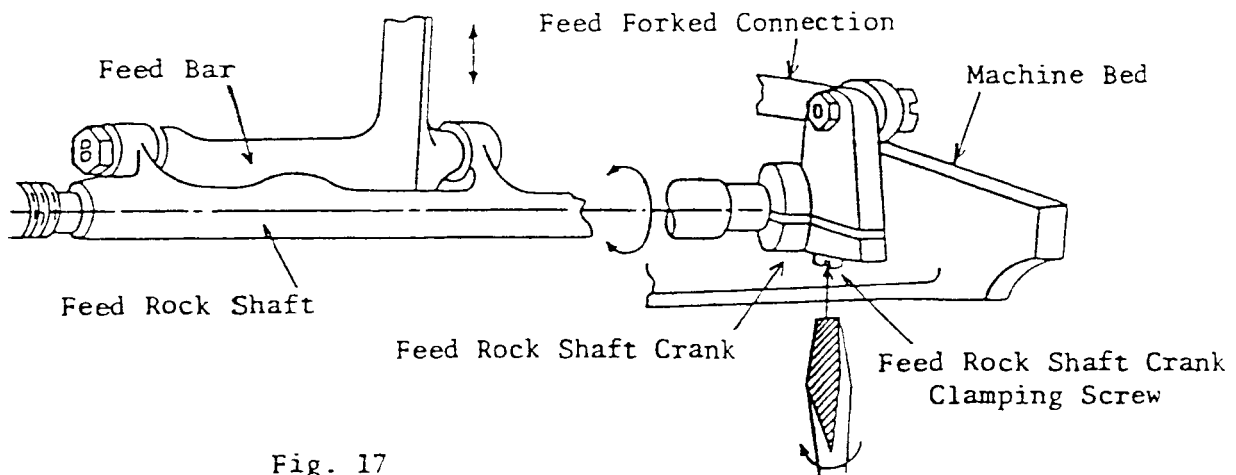

Fig. 17

Feed dog should be set so that its movement is equidistant from front and rear edges of throat plate slots, or have at least 1 mm clearance as shown in Fig. 18 when it is located nearest to the front of machine.

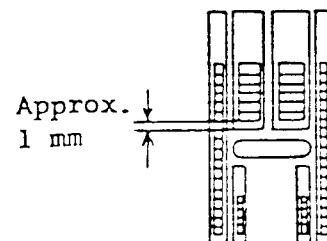

Fig. 18

## SIDEWISE SETTING:

When feed dog contacts edges of throat plate slots (Fig. 19), set feed dog in correct position as instructed below.

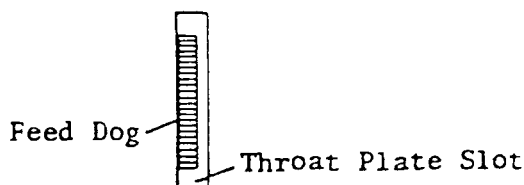

Fig. 19-a

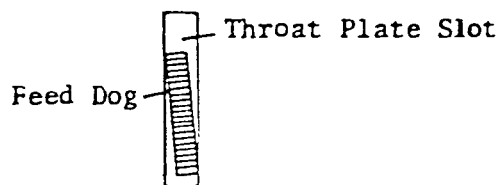

Fig. 19-b

1. If feed dog contacts the edges of throat plate slots (Fig. 19-a), this condition can be corrected by moving feed dog toward left or right, as required, after loosening two nuts on two screw centers.
  - a. To move feed dog toward left, loosen screw center at left end of feed rock shaft (Fig. 20), as required, and tighten the other screw center an equal amount.
  - b. To move feed dog toward right, loosen screw center at right end of feed rock shaft, as required, and tighten the other screw center an equal amount.

Feed dog should travel midway between sides of throat plate slots.

Screw centers must hold feed rock shaft snugly in place without binding.

Securely tighten both screw center nuts.

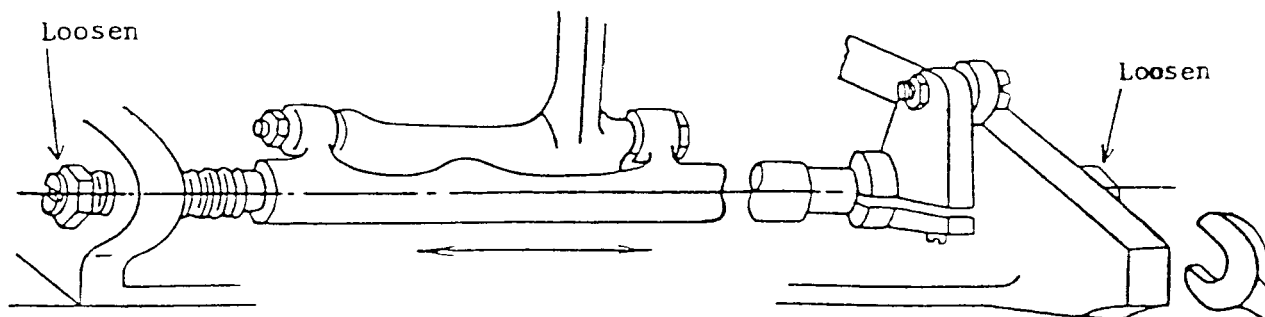

Fig. 20

2. If feed dog contacts the edges of throat plate slots at an angle (Fig. 19-b), correct its setting as instructed below.
  - a. Tip machine back and remove bed plate by pushing it from the underside with the point of a screwdriver.

- b. Loosen the two feed dog screws. (Fig. 21)
- c. Set feed dog in correct position and securely tighten the two screws.
- d. Replace bed plate and press it firmly in place.

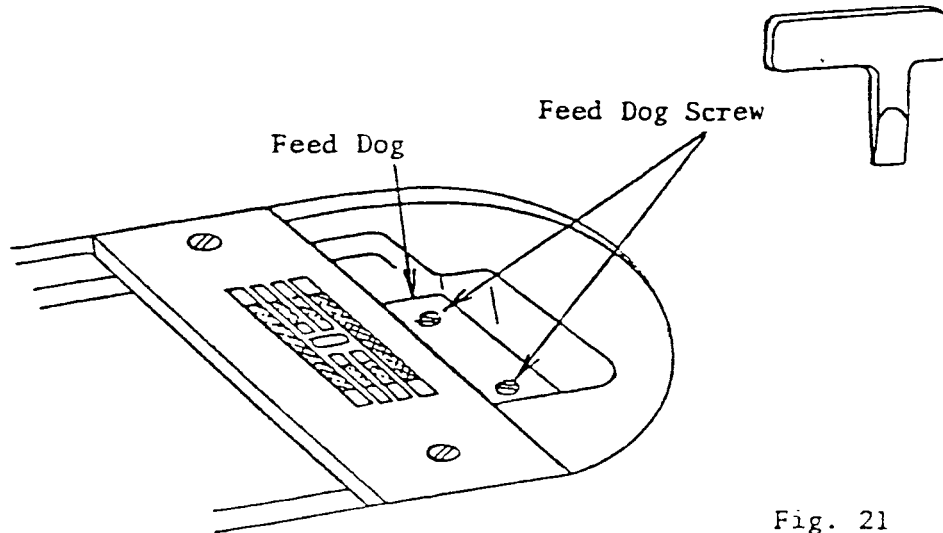

Fig. 21

#### TO SET PRESSER BAR AT CORRECT HEIGHT

##### CHECK:

1. When presser bar is in its raised position there should be a clearance of 6.35 mm between underside of presser foot and top surface of throat plate. (Fig. 22)
2. When presser bar is at its highest point and needle bar at its lowest, top of presser foot should clear the lower end of needle bar.

##### SETTING:

1. Remove needle, and loosen presser bar pressure regulating thumb screw to decrease spring tension.
2. Turn machine pulley toward you to lower feed dog below throat plate surface.
3. Raise presser bar lifter and loosen presser bar guide bracket set screw.
4. Place a block approximately 6.35 mm thick on top of throat plate, and bring presser foot down to rest firmly upon the block. (Fig. 22)
5. Make sure the presser bar guide bracket is firmly in contact with presser bar lifter, then lightly tighten guide bracket set screw. (Fig. 23)

6. Remove block, lower presser bar lifter, and make certain presser bar is positioned correctly so that needle will locate centrally between the toes of the presser foot.
7. Securely tighten guide bracket set screw.
8. Raise presser bar lifter, turn machine pulley and make sure lower end of needle bar does not interfere with presser foot.

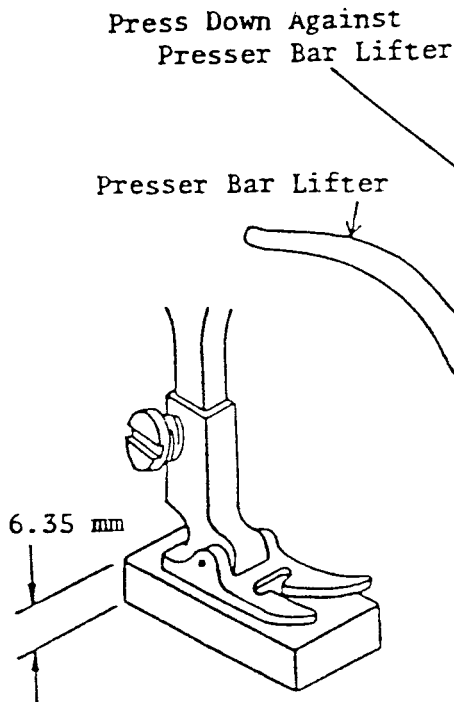

Fig. 22

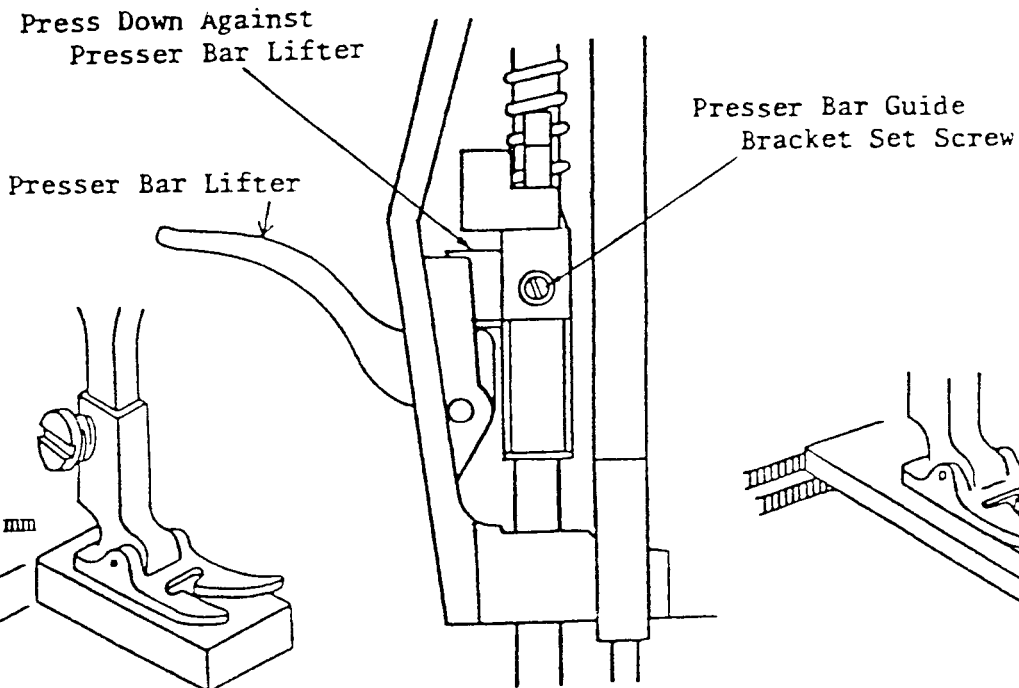

Fig. 23

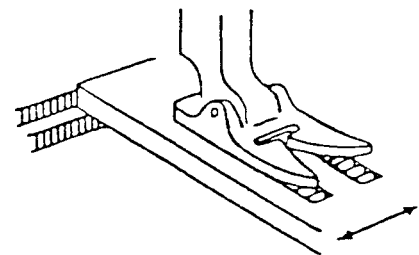

Fig. 24

#### TIMING THE FEED

The motion of feed dog in relation to the needle should be as follows.

1. The feed dog should rise above throat plate surface when needle rises approximately half way of its upward stroke. (Fig. 25-a)
2. The feed dog should start to move forward (away from you) just before the needle reaches its highest point. (Fig. 25-b)
3. The feed dog should be descending and just about to go below the throat plate surface when needle descends to a point level with the top surface of throat plate. (Fig. 25-c)

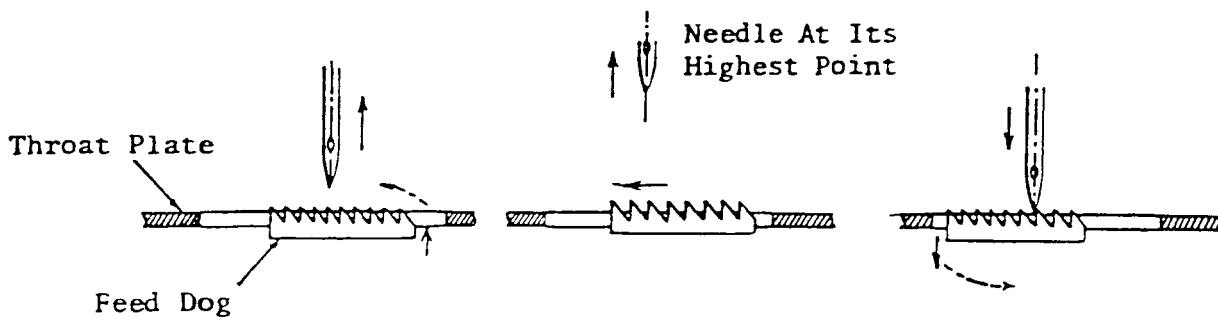

Fig. 25-a

Fig. 25-b

Fig. 25-c

If the location of feed and feed lifting eccentric has been accidentally disturbed, reset as instructed below.

SETTING:

1. Turn machine pulley toward you until the second of the two screws on the feed and feed lifting eccentric appears in sight.
2. Adjust feed and feed lifting eccentric so that the point of second screw, namely the feed and feed lifting eccentric position screw, will locate in the V groove provided on the arm shaft, and securely tighten position screw.
3. Then the first screw, namely the feed and feed lifting eccentric set screw, should also be securely tightened.

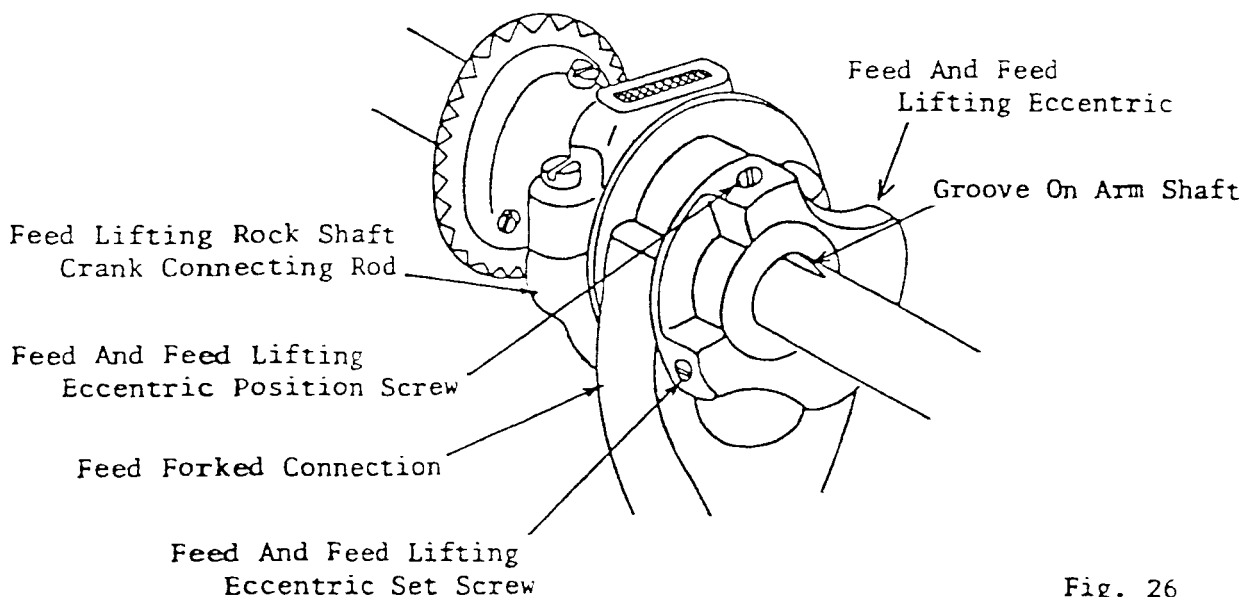

Fig. 26

POSITIONING THE FEED AND FEED LIFTING ECCENTRIC,  
FEED FORKED CONNECTION, FEED ROCK SHAFT CRANK,  
FEED LIFTING ROCK SHAFT CRANK CONNECTING ROD  
AND FEED LIFTING ROCK SHAFT CRANK

If for any reason, it is necessary to make sidewise adjustment of the above parts, it should be adjusted in the following manner.

ADJUSTMENT:

1. To adjust feed and feed lifting eccentric in relation to feed forked connection, loosen feed and feed lifting eccentric position screw and set screw and move feed and feed lifting eccentric to the left or right as required, then securely tighten the screws when correctly positioned. Make sure that the feed forked connection and feed and feed lifting eccentric is free from binding.

(Refer to "TIMING THE FEED" on page 18 in regard to setting angle of feed and feed lifting eccentric on arm shaft.)

2. The feed forked connection should be set squarely to the feed rock shaft. To set feed forked connection in correct position, loosen feed rock shaft crank clamping screw and move feed rock shaft crank to the left or right as required, then securely tighten clamping screw when correct position is obtained.

(If setting angle of feed rock shaft crank on feed rock shaft need to be reset due to making the above adjustment, adjust as instructed on page 15 under "LENGTHWISE SETTING" of feed dog.)

3. The feed lifting rock shaft crank should be set so that the feed lifting rock shaft crank connecting rod would be square to the feed lifting rock shaft and also function without binding. To set in correct position, loosen crank clamping screw and move feed lifting rock shaft crank to the left or right as required, then securely tighten clamping screw.

(If it becomes necessary to reset the setting angle of feed lifting rock shaft crank on the feed lifting rock shaft due to making the above adjustment, adjust as instructed under "TO SET FEED DOG AT CORRECT HEIGHT" on page 14.)

ADJUSTMENT OF TENSION

Tension on needle thread should be just enough to set stitch properly in material. For ordinary stitching, a correct stitch can be obtained to suit the work in process by varying tension on needle thread only.

If a properly balanced stitch can not be obtained by varying the needle thread tension, check whether or not the thread handling parts such as the slack thread regulator, thread take-up lever, tension discs, etc. are smoothly finished.

## A. THREAD TAKE-UP SPRING TENSION

Tension on thread take-up spring should be sufficient to ensure action at top speed, but still light enough to permit itself to be drawn all the way down (as take-up lever approaches the top of its stroke) before any thread is drawn through the tension discs.

NOTE: The tension on the thread take-up spring may require different settings depending upon the size of thread used. Heavier thread requires more tension to ensure correct thread control.

### SETTING:

1. Thread the machine.
2. Check to see that the thread take-up spring regulator set screw is tight.
3. Make certain the tension regulating thumb nut is on the stud.
4. To adjust tension, insert a large screwdriver in the slot of the tension stud. Turn stud to the left to decrease tension or to the right to increase tension.

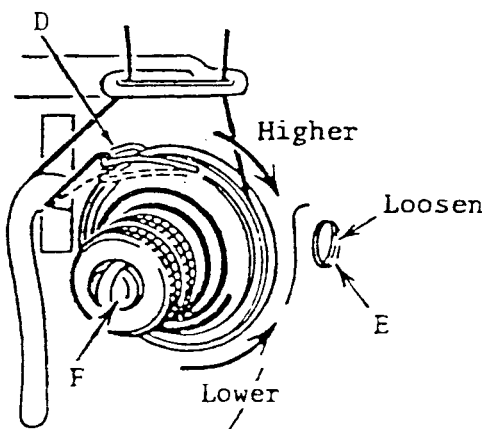

Fig. 27

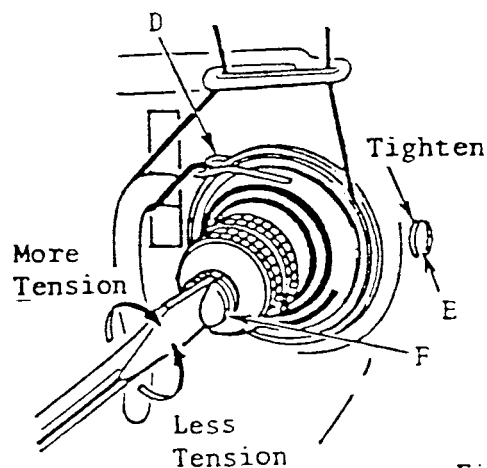

Fig. 28

## B. THREAD TAKE-UP SPRING HEIGHT

Thread the machine and turn machine pulley toward you. When take-up lever begins to rise, the thread take-up spring should make a slight dip (approx. 0.8 mm), then after a short dwell, return to its original position. As the take-up lever approaches the top of its stroke, setting the stitch, the thread take-up spring should be drawn all the way down.

As the take-up lever descends, the thread take-up spring should return to its original position.

The movement of the thread take-up spring may require to be increased when sewing with thread that stretches or when sewing wide zigzag stitches.

## SETTING:

1. Loosen thread take-up spring regulator set screw.
2. Using a large screwdriver in slot of tension stud, turn stud (at the same time turning entire tension assembly) either over toward left to lower thread take-up spring and decrease its movement, or over toward right to raise thread take-up spring and increase its movement.
3. Securely tighten thread take-up spring regulator set screw.

## ADJUSTMENT OF BACKLASH

### CHECK:

When zigzag triangular cam gear is properly set in position in relation to the arm shaft (horizontal) worm gear, there should be a slight amount of backlash.

Hold arm shaft worm gear immovable by holding machine pulley, and feel for backlash by moving zigzag triangular cam sidewise with finger. If there is too much play and/or not enough backlash, adjust as instructed below.

### ADJUSTMENT:

1. Remove two arm top cover screws and lift off cover and loosen zigzag triangular cam shaft set screw. (Fig. 30)
2. While feeling the play between the gears, turn zigzag triangular cam shaft (eccentric) with a large screwdriver either over toward left (to decrease backlash), or over toward right (to increase backlash) as required, until there is just a slight amount of backlash. Then securely tighten set screw.
3. Turn machine pulley and check torque. Also re-check the backlash.

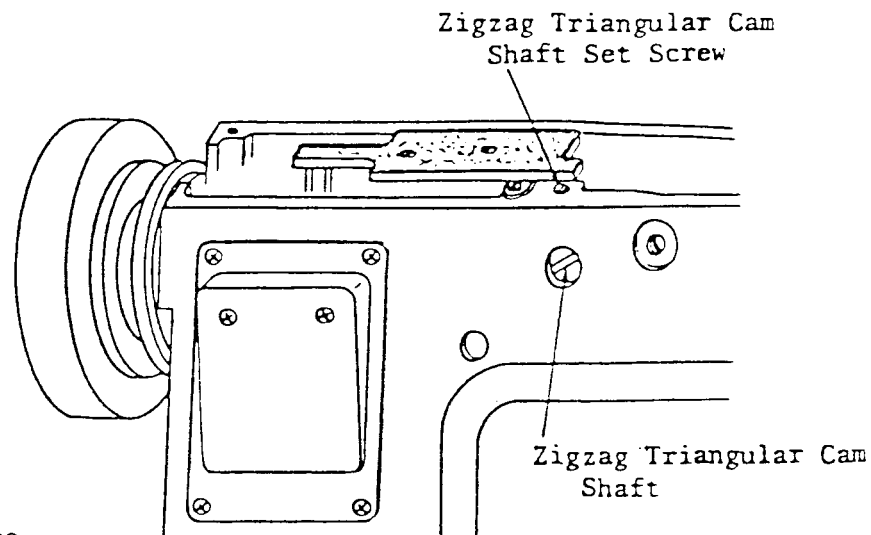

Fig. 29